



Inventario de ejercicios, problemas y actividades de Matemática (primer grado de secundaria) (Apoyo a la recuperación académica 2017)

Estimado estudiante:

Te proponemos el presente inventario de ejercicios y problemas (actividades para otras áreas) como un recurso de apoyo para el proceso de recuperación académica que debes seguir durante el mes de enero de 2018. Te pedimos tener presente que:

- El inventario ha sido elaborado de acuerdo con el temario de la evaluación de salida del cuarto bimestre.
- Los ejercicios y problemas que se presenta en el inventario han sido tomados de:
 - los documentos de trabajo del año escolar 2017
 - otras fuentes, pero que se ajustan a los contenidos del temario.
- El inventario ha sido dosificado para ser desarrollado en cuatro semanas, de lunes a viernes, destinando para ello una hora diaria aproximadamente.
- El inventario debe ser desarrollado en pliegos de papel oficio cuadriculado. Su presentación será en un folder manila tamaño oficio (incluir carátula), el mismo que será revisado y evaluado por los docentes responsables de la evaluación de recuperación, asignándole un peso de 25 % en el resultado final de la recuperación como "evaluación de portafolio". De hecho, si no presentases el cuaderno con el inventario desarrollado, se te asignará la nota mínima en evaluación de portafolio.
- Si los estudiantes requiriesen presentarse a la segunda oportunidad, podrán mejorar y volver a presentar el inventario desarrollado, prevaleciendo, en este caso, la segunda calificación. Si no lo hiciesen, mantendrán la calificación obtenida en la primera ocasión.
- En la tabla de control diario, el padre de familia debe firmar para apoyar y controlar el avance diario del estudiante en el desarrollo del inventario.
- No hemos incluido una calendarización específica para el desarrollo del inventario (fechas de inicio y fin), asumiendo que cada estudiante lo hará en coordinación con sus padres, considerando la realidad particular y los planes de la familia. En todo caso, el trabajo ha sido previsto para cuatro semanas.
- La primera oportunidad de evaluación será a fines de enero. La presentación del portafolio con el inventario desarrollado es obligatoria desde la primera oportunidad de evaluación.

Semana 1

Contenido: Probabilidad de un suceso

- Leonardo compró 5 números de una rifa, la cual contiene 25 números. ¿Qué probabilidad hay que Diego gane?
A. 10 % B. 20 % C. 25 % D. 30 % E. 50 %
- Se lanza al aire un dado icosaédrico con las caras numeradas del 1 al 20. ¿Cuál es la probabilidad de obtener un número mayor o igual a 11?
A. 25 % B. 55 % C. 45 % D. 50 % E. 51 %
- Se lanza al aire tres monedas. Calcula la probabilidad de obtener al menos dos sellos.
A. 30 % B. 40 % C. 50 % D. 20 % E. 60 %
- En una bolsa hay 10 bolas numeradas del 11 al 20, idénticas salvo en el color, pues unas son rojas y otras son verdes. Sacamos sin mirar una bola. ¿Cuál es la probabilidad de obtener un número primo?
A. 25 % B. 35 % C. 40 % D. 45 % E. 50 %
- Del problema anterior, se sabe que la probabilidad de sacar una bola verde es $\frac{3}{5}$. ¿Cuántas bolas de cada color hay?
A. 6 rojas y 4 verdes B. 4 rojas y 6 verdes C. 3 verdes y 7 rojas D. 7 verdes y 3 rojas E. 5 de cada color
- Se extrae una carta al azar de un naipe inglés (52 cartas). ¿Cuál es la probabilidad de obtener un número mayor que 10 de color negro?
A. 11,5 % B. 18,5 % C. 21,5 % D. 25 % E. 32 %

18. La altura total de un poste es de 57,4 m. En la superficie hay 37,9 m, la quinta parte de lo que queda está sumergida en concreto y el resto bajo tierra. ¿Qué cantidad está bajo tierra?

- A. 15,6 m B. 3,9 m C. 16,6 m D. 18,7 m E. 2,5 m

Contenido: Ecuaciones de primer grado con una variable

Calcula el valor de la variable de las ecuaciones propuestas.

19. $5x - \{6x + [8 - (x + 1)]\} = -2x + 1$

- A. 4 B. 2 C. 6 D. 8 E. 10

20. $7 - 3(x + 1) = x - 3(x - 1)$

- A. 1 B. 3 C. 5 D. 7 E. 9

21. $\frac{x+3}{6} - \frac{x+4}{8} = \frac{3(x+5)}{36}$

- A. -2 B. -4 C. -6 D. -8 E. -10

22. $\frac{8x}{3} + \frac{1}{2} = \frac{5x}{4} - 2$

- A. -10/17 B. -20/17 C. -30/17 D. -14 E. -8

23. $3 + \frac{3x}{7} - \frac{2x}{15} = \frac{x}{3} + \frac{13}{3}$

- A. -12 B. -15 C. 35 D. -35 E. 15

24. $\frac{x+3}{4} - \frac{x-1}{2} = \frac{x}{6} + 1$

- A. 2/5 B. 3/5 C. 4/5 D. 1/5 E. 1

25. $\frac{7x-6}{3} - (x+2) = 4x+2$

- A. 3/4 B. 7/5 C. 3/7 D. -9/4 E. -3/7

26. $\frac{4(3x+6)}{5} + 3 = \frac{2(2x+5)}{3} - 3x$

- A. -61/67 B. -67/65 C. -67/61 D. -32/21 E. 57/54

27. $\frac{6x+1}{12} - \frac{x-13}{9} = \frac{5x-3}{2} + \frac{x}{30}$

- A. 454/386 B. 545/368 C. 545/386 D. 445/386 E. 545/398

Tabla de respuestas de la semana 2							
13.	E	14.	C	15.	A	16.	C
17.	D	18.	A	19.	A	20.	A
21.	E	22.	C	23.	D	24.	B
25.	D	26.	C	27.	C		

Tabla de firmas del padre de familia de control diario de la semana 2				
Lunes 8 de enero	Martes 9 de enero	Miércoles 10 de enero	Jueves 11 de enero	Viernes 12 de enero

Contenido: Problemas con ecuaciones

28. En la ferretería "Todo barato" se venden tornillos en cajas de tres tamaños: pequeña, mediana y grande. La caja grande contiene el doble de tornillos de la mediana y la mediana, 25 tornillos más que la pequeña. He comprado una caja de cada tamaño y en total hay 375 tornillos, ¿cuántos tornillos hay en la caja mediana?
- A. 50 B. 75 C. 150 D. 175 E. 100
29. Para una fiesta se han comprado 340 refrescos de sabores naranja, fresa y limón. De naranja hay el triple que de fresa, de limón, el doble que de fresa, menos 20. ¿Cuántos refrescos de limón hay?
- A. 100 B. 150 C. 160 D. 70 E. 80
30. En un avión viajan 240 pasajeros de tres países: españoles, alemanes y franceses. Hay 30 franceses más que alemanes y de españoles hay el doble que de franceses y alemanes juntos. ¿Cuántos pasajeros franceses viajan?
- A. 75 B. 40 C. 220 D. 80 E. 55
31. Ricardo repartió su dinero de la siguiente manera: la mitad para su esposa, la tercera parte para su hijo, la octava parte para su sobrina y 180 soles a una institución benéfica ¿Cuánto dinero poseía?
- A. S/ 3400 B. S/ 4230 C. S/ 4023 D. S/ 3500 E. S/ 4320
32. Leo tiene 30 años más que Luis y dentro de 7 años tendrá el triple. ¿Qué edad tiene Leo?
- A. 8 B. 38 C. 24 D. 28 E. 16
33. La diferencia de edad entre dos hermanos es de 5 años y dentro de 2 años uno tendrá doble que el otro. ¿Qué edad tiene el mayor?
- A. 8 B. 14 C. 12 D. 16 E. 18
34. Ana tiene 36 años menos que su padre y dentro de 8 años, su padre tendrá el cuádruple de los que entonces tenga ella. ¿Qué edad tiene cada uno en la actualidad?
- A. 4 y 40 B. 2 y 42 C. 6 y 36 D. 10 y 48 E. 12 y 39
35. Juan le preguntó a María cuántos años tenía y ésta le respondió: "El doble de los años que tenía hace 5 años más los que tengo ahora es igual al cuádruple de los que tenía hace 10 años". ¿Cuántos años tenía María hace 7 años?
- A. 23 B. 30 C. 25 D. 20 E. 10
36. Hace 15 años la edad de Luisa era $\frac{2}{5}$ de la edad que tendrá dentro de 15 años. ¿Qué edad tiene ahora Luisa?
- A. 15 B. 25 C. 35 D. 45 E. 55
37. Después de gastar las $\frac{4}{7}$ partes de un depósito quedan 78 litros. ¿Cuál es la capacidad del depósito?
- A. 127 B. 132 C. 152 D. 182 E. 162
38. Juana tiene 400 soles y Rosa tiene 350 soles. Después de comprar las dos el mismo libro a Rosa le queda las $\frac{5}{6}$ partes de lo que le queda a Juana. ¿Cuál es el precio del libro?
- A. 100 B. 150 C. 200 D. 175 E. 250
39. Halla el valor del ángulo A de un triángulo ABC sabiendo que B mide 40° más que C y que A mide 40° más que B.
- A. 120° B. 115° C. 100° D. 125° E. 130°
40. Preguntado el padre por la edad de su hijo contesta: "si al doble de los años que tiene se le quita el triple de los que tenía hace 6 años, se tendrá su edad actual". ¿Cuál es la edad del hijo actualmente?
- A. 9 B. 10 C. 11 D. 12 E. 13
41. Ester tiene el triple de dinero que Ana y la mitad que Héctor. Héctor les da a Ana y a Ester 25 euros a cada una. Ahora Ester tiene la misma cantidad que Héctor. ¿Cuánto dinero tenía Ester al principio?
- A. 25 B. 50 C. 75 D. 100 E. 125
42. En una empresa trabajan 160 personas y todas ellas deben someterse a un reconocimiento médico en el plazo de tres días. El primer día lo hace la tercera parte de los que lo hacen durante los otros dos días. El segundo y el tercer día lo hacen el mismo número de personas. Calcula el número de trabajadores que acuden al reconocimiento el primer día.
- A. 30 B. 40 C. 50 D. 60 E. 80

Tabla de respuestas de la semana 3

28.	E	29.	A	30.	E	31.	E
32.	B	33.	A	34.	A	35.	A
36.	C	37.	D	38.	A	39.	C
40.	A	41.	C	42.	B		

Tabla de firmas del padre de familia de control diario de la semana 3

Lunes 15 de enero	Martes 16 de enero	Miércoles 17 de enero	Jueves 18 de enero	Viernes 19 de enero

Semana 4

Contenido: Ángulos: propiedades y teoremas

43. En la figura, halla el valor de "θ", si se sabe que: $\alpha = x + 5^\circ$; $\beta = x + 20^\circ$; $\theta = 4x + 10^\circ$; $\phi = 100^\circ - x$.

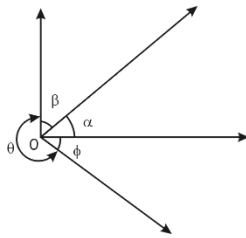

- A. 45° B. 50° C. 70° D. 190° E. 130°

44. En la figura, halla el valor del ángulo BOC, si $m \sphericalangle AOD$ es 123° .

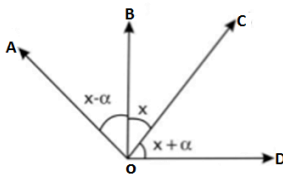

- A. 82° B. 40° C. 63° D. 41° E. 45°

45. En la figura, halla el valor del ángulo MOC, si $m \sphericalangle BOC - m \sphericalangle AOC = 40^\circ$ y además \overline{OM} es bisectriz del ángulo AOB.

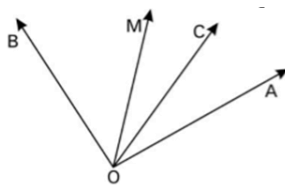

- A. 30° B. 5° C. 25° D. 10° E. 20°

46. Si $m \sphericalangle BOD = 120^\circ$, halla la medida del ángulo formado por las bisectrices de AOB y COD.

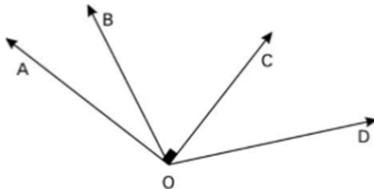

- A. 90° B. 100° C. 110° D. 105° E. 120°

47. En la figura, calcula el valor de "x"

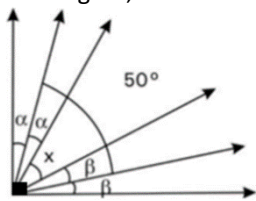

- A. 10° B. 15° C. 20° D. 25° E. 30°

48. En la figura, calcula el valor del ángulo BOD, si $m\angle AOC = 100^\circ$ y $m\angle XOY = 80^\circ$.

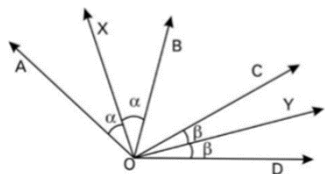

- A. 50° B. 90° C. 70° D. 60° E. 120°

49. En la figura, calcula el valor de "x".

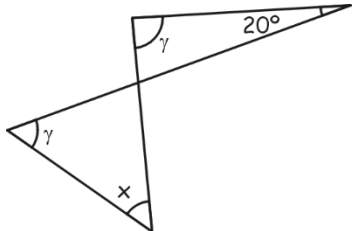

- A. 14° B. 25° C. 20° D. 90° E. 18°

50. En la figura, calcula el valor de "x".

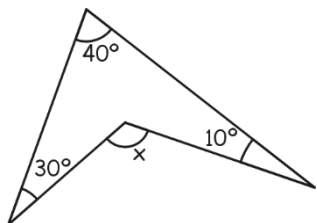

- A. 40° B. 80° C. 60° D. 45° E. 90°

51. En la figura, calcula el valor de "x".

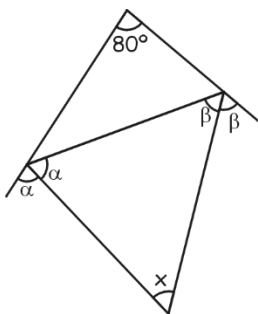

- A. 50° B. 80° C. 140° D. 130° E. 260°

52. En la figura, calcula el valor de "x".

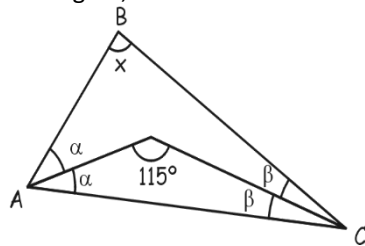

- A. 50° B. 45° C. 125° D. 95° E. 70°

53. En la figura, calcula el valor de "x".

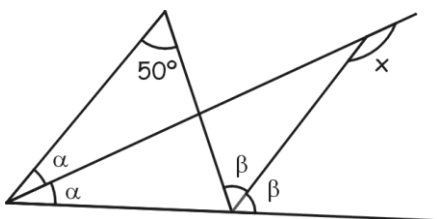

- A. 125° B. 135° C. 145° D. 155° E. 165°

54. Se tiene los ángulos adyacentes AOB y BOC de modo que $m\angle AOB - m\angle BOC = 48^\circ$, luego se trazan las bisectrices \overline{OM} del ángulo AOB, \overline{ON} del ángulo BOC y \overline{OS} del ángulo MON. Calcula la medida del ángulo SOB.
- A. 48° B. 32° C. 18° D. 24° E. 12°
55. Se tienen los ángulos consecutivos AOB, BOC y COD. Además, se sabe que $m\angle AOC = 50^\circ$, $m\angle BOD = 30^\circ$ y $m\angle AOD = 70^\circ$, halla $m\angle BOC$.
- A. 10° B. 20° C. 25° D. 30° E. 35°
56. La suma de las medidas de dos ángulos es 80° y el complemento del primer ángulo es el doble de la medida del segundo ángulo. Calcula la diferencia de las medidas de dichos ángulos.
- A. 60° B. 10° C. 70° D. 50° E. 40°
57. La sexta parte del suplemento del complemento de un ángulo es igual a la mitad de la cuarta parte del suplemento del complemento de 50° . Halla la medida del ángulo.
- A. 15° B. 18° C. 20° D. 35° E. 50°
58. La suma de los complementos de dos ángulos es 130° y la diferencia de sus suplementos de los mismos ángulos es 10° . Calcula la medida del ángulo mayor.
- A. 10° B. 20° C. 30° D. 40° E. 50°
59. El suplemento del complemento del suplemento de la medida de un ángulo es igual a ocho veces la medida del ángulo. Encuentra el suplemento del triple de la medida del ángulo.
- A. 30° B. 60° C. 90° D. 110° E. 120°
60. El duplo del suplemento de un ángulo es igual al suplemento de la diferencia entre el suplemento y el complemento del ángulo. Calcula la medida del ángulo.
- A. 135° B. 175° C. 155° D. 125° E. 150°

Tabla de respuestas de la semana 4							
43.	D	44.	D	45.	E	46.	D
47.	A	48.	D	49.	C	50.	B
51.	A	52.	A	53.	D	54.	E
55.	A	56.	A	57.	A	58.	C
59.	C	60.	A				

Tabla de firmas del padre de familia de control diario de la semana 4				
Lunes 22 de enero	Martes 23 de enero	Miércoles 24 de enero	Jueves 25 de enero	Viernes 26 de enero



Inventario de ejercicios, problemas y actividades de Comunicación (primer grado de secundaria) (Apoyo a la recuperación académica 2017)

Estimado estudiante:

Te proponemos el presente inventario de ejercicios y problemas (actividades para otras áreas) como un recurso de apoyo para el proceso de recuperación académica que debes seguir durante el mes de enero de 2018. Te pedimos tener presente, respecto al inventario, lo siguiente:

- Ha sido elaborado de acuerdo con el temario de la evaluación de salida del cuarto bimestre.
- Los ejercicios y problemas que se presenta en él han sido tomados de los documentos de trabajo del año escolar 2017 y de otras fuentes, pero que se ajustan a los contenidos del temario.
- Ha sido dosificado para ser desarrollado en cuatro semanas, de lunes a viernes, destinando para ello una hora diaria aproximadamente.
- Debes imprimir el presente documento y desarrollar los ejercicios propuestos. Su presentación será en un fólder manila tamaño oficio (incluir carátula), el mismo que será revisado y evaluado por los docentes responsables de la evaluación de recuperación, asignándole un peso de 25 % en el resultado final de la recuperación como "evaluación de portafolio". De hecho, si no lo presentares desarrollado, se te asignará la nota mínima en evaluación de portafolio.
- Si los estudiantes requiriesen presentarse a la segunda oportunidad, podrán mejorar y volver a presentarlo desarrollado, prevaleciendo, en este caso, la segunda calificación. Si no lo hiciesen, mantendrán la calificación obtenida en la primera ocasión.
- En la tabla de control diario, el padre de familia debe firmar para apoyar y controlar el avance diario del estudiante en su desarrollo.
- No hemos incluido una calendarización específica para su desarrollo (fechas de inicio y fin), asumiendo que cada estudiante lo hará en coordinación con sus padres, considerando la realidad particular y los planes de la familia. En todo caso, el trabajo ha sido previsto para cuatro semanas.
- La primera oportunidad de evaluación será a fines de enero. La presentación del portafolio (inventario desarrollado) es obligatoria desde la primera oportunidad de evaluación.

Semana 1

Tema	Páginas	Ejercicios y actividades	Firma
Análisis de textos continuos	3-4	ANEXO 01	
Razonamiento verbal: sinónimos y antónimos	4-5		
Análisis de textos discontinuos: la imagen	5		
Producción de textos: el afiche	5-6		

Semana 2

Tema	Páginas	Ejercicios y actividades	Firma
Análisis de textos continuos	7-8	ANEXO 02	
Teoría literaria: géneros y especies literarios, el género lírico	9		
Razonamiento verbal: significado lexical y contextual, ideas principales y secundarias, analogías	10		
Producción de textos: texto expositivo	11		

Semana 3

Tema	Páginas	Ejercicios y actividades	Firma
Análisis de textos continuos	12	ANEXO 03	
Análisis de textos discontinuos: el afiche	13		
Teoría literaria: géneros y especies literarios	13		
Producción de textos: la historieta	14		

Semana 4

Tema	Páginas	Ejercicios y actividades	Firma
Análisis de textos continuos	15	ANEXO 04	
Teoría literaria: el texto lírico	16		
Razonamiento verbal: significado lexical y contextual, antónimos	17		
Análisis de textos discontinuos: el afiche	18		

Ejercicios adicionales	19-20-21-22	ANEXO 05	
------------------------	-------------	----------	--

ANEXO 01

ANÁLISIS DE TEXTOS CONTINUOS

I. Lee atentamente los textos; luego, sobre la base de su contenido, desarrolla las indicaciones propuestas.

TEXTO 01

- Mamá-, dijo el niño mirando a la madre en la cara-, ¡eres muy bella!
La madre sonrió complacida, pues, un halago siempre es dulce en los labios de un niño.
- Sí, - continuó el niño- no hay en todo el mundo una mamá más linda... menos en las manos.
- No las mires, pues son tan feas -dijo-.
- No puedo evitarlo. Cada vez que las toco, tengo que mirarlas; son manos enrojecidas y cubiertas de cicatrices. ¡Oh, si fueran lindas como tu cara!
El padre llamó aparte al niño y le dijo:
-Te contaré una historia: una noche una criatura dormía en su cuna. Debido a un descuido, tomaron fuego las cortinas de la cuna, que en un instante quedó envuelto en llamas. La sirvienta salió corriendo de la habitación, pero la madre se precipitó y con sus manos blancas apagó el fuego y salvó a la criatura. Esas manos recibieron terribles quemaduras. Durante semanas estuvieron vendadas y sin poder servir. Cuando cicatrizaron las llagas, las manos eran...
Pero el niño no esperó el fin del relato corrió hacia la cocina para arrodillarse junto a la madre y tomándole las manos rojas y cubiertas de cicatrices, las besó repetidas veces, diciendo:
- ¡Mamá, tus manos son las más bellas del mundo!

Encar Catatá

NIVEL LITERAL

1. El personaje principal es:

- A. La nana B. El niño C. Las manos D. El padre E. La sirvienta

2. Son características actitudinales de la madre:

- A. Soberbia, caritativa y resentida
B. Inocente y ama de casa
C. Soñadora, insegura y egoísta
D. Atenta, amorosa y comprensiva
E. Astuta y muy respetuosa

3. Es uno de los escenarios mencionados en el texto:

- A. La recepción B. La cocina C. La sala D. El comedor E. La casa

4. Es un hecho principal del cuento:

- A. Al producirse el fuego, la sirvienta salió huyendo de la habitación.
B. El niño se arrodilló ante el padre pidiendo perdón.
C. La madre contó al niño el porqué de sus cicatrices en las manos.
D. Después del relato de su padre, el niño honró las manos de la madre como las más bellas del mundo.
E. El padre explicó al niño las consecuencias de las cicatrices de su madre.

NIVEL INFERENCIAL

5. Idea que se puede deducir del hecho subrayado.

- A. La sirvienta era muy miedosa al fuego.
B. La sobreprotección entre padres e hijos es recíproca.
C. Debemos valorar los sacrificios de los padres.
D. Los seres humanos tenemos defectos físicos.
E. El amor paternal muchas veces se manifiesta en sacrificios.

6. El tema del texto leído es:

- A. El sacrificio B. El amor fraternal C. El desinterés D. El miedo E. El remordimiento

7. El mensaje del texto es:

- A. Debemos valorar a las personas por sus actitudes mas no por su físico.
B. Tenemos que corregir a nuestros hijos antes que sea demasiado tarde.
C. Criticar a los demás no conduce a algo bueno.
D. Debemos buscar siempre la paz interior en el corazón.
E. Reflexiona sobre tus actos indebidos, pues nunca conducen a algo bueno.

NIVEL CRÍTICO

8. ¿Cómo se relaciona el contenido de la obra con los hechos de la realidad? Fundamenta tu respuesta.

.....
.....
.....

TEXTO 02

Es un desorden alimenticio que amenaza la vida y se caracteriza por la privación de comer y por la pérdida excesiva de peso. El desorden es diagnosticado cuando una persona pesa por lo menos el 15 por ciento menos del peso normal de su cuerpo.

Las personas con anorexia nerviosa tienen intensos temores a engordar y se ven a sí mismos gordos, inclusive cuando están muy delgados. Estos individuos pueden tratar de corregir esta percibida "imperfección" limitando el consumo de alimento de manera estricta y haciendo excesivo ejercicio con la finalidad de perder peso.

Las personas con anorexia nerviosa tienden a ser personas que obtienen altos logros y se desempeñan muy bien en la escuela, los deportes, el trabajo y en otras actividades. Ellos podrían dejar de comer para sentir que tienen control sobre alguna parte de sus vidas o podrían rechazar la comida para "rebelarse" contra sus seres queridos.

Los desórdenes alimenticios son más comunes en las mujeres que en los hombres. El riesgo de desarrollar un desorden alimenticio es más grande en actores, modelos, bailarines y atletas de deportes en los que la apariencia y/o el peso son importantes; por ejemplo: lucha libre, gimnasia y patinaje sobre hielo.

http://my.clevelandclinic.org/es/_disorders/anorexia_nervosa/hic_anorexia_nervosa.aspx

NIVEL LITERAL

1. Utilizando llaves o corchetes, señala la estructura textual.
2. Mediante la técnica del subrayado identifica las ideas principales del texto. Luego, elabora el respectivo resumen.

NIVEL INFERENCIAL

3. Una idea que se puede inferir del texto es:
 - A. No debemos preocuparnos por el aspecto interior.
 - B. Para ser personas exitosas es muy importante tener una bonita figura.
 - C. Es difícil para los bailarines engordar.
 - D. En la actualidad, a la mayoría de personas les importa el aspecto físico.
 - E. Los desórdenes alimenticios son más comunes en los hombres.

NIVEL CRÍTICO

4. ¿Qué recomendación darías para prevenir la anorexia? Fundamenta tu respuesta.

RAZONAMIENTO VERBAL

II. Lee los siguientes ejercicios y desarróllalos, según corresponda.

1. Marca la alternativa que contenga los SINÓNIMOS de las palabras destacadas en negrita.

A. PRESTEZA A. dejadez B. esfuerzo C. ligereza D. seguridad E. energía	B. RECELO A. perjuicio B. odio C. desconfianza D. pánico E. bienestar
C. Llevé un obsequio a mi apreciado amigo. A. donativo - gran B. regalo - estimado C. legado - amado D. subvención - cariñoso E. presente - valorado	2. La homenajeadada recibió con cariño y cordialidad a los invitados. A. tendencia - sencillez B. voluntad - bondad C. afecto - amabilidad D. devoción - humanidad E. predilección - simpatía

3. Escribe, en las líneas punteadas, un sinónimo perteneciente al lenguaje formal que reemplace a cada palabra subrayada en las oraciones.

- Tus nuevas zapatillas están bacanes.
- A fin de mes tendré mucho villegas.

4. Forma dos grupos con las palabras del recuadro. Luego, copia cada grupo ordenando las palabras de menor a mayor intensidad.

BIENESTAR	OPULENCIA
RUIDO	RIQUEZA
RUMOR	ESTRÉPITO

GRUPO 1	GRUPO 2
.....
.....
.....

5. Identifica el ANTÓNIMO de las palabras propuestas.

VIEJO A. anciano B. abuelo C. mocetón D. vejestorio E. longevo

ATREVIDO A. audaz B. osado C. cobarde D. emprendedor E. resuelto

ANÁLISIS DE TEXTOS DISCONTINUOS

III. Observa la siguiente imagen e indica sus significados, plano, ángulo y clasificación, según se propone.

	SIGNIFICADO DENOTATIVO	CLASIFICACIÓN
	SIGNIFICADO CONNOTATIVO	1. Por su movimiento:
	ÁNGULO	2. Por su complejidad:
.....	PLANO

PRODUCCIÓN DE TEXTOS

IV. Elabora un afiche sobre el tema "La contaminación ambiental" y señala cada una de sus partes. Ten en cuenta los indicadores mencionados.

Presentación	Caligrafía	Ortografía		Estructura	Contenido	Creatividad
		Letras-tildes	Puntuación			
0-2	0-2	0-5	0-3	0-4	0-2	0-2

AFICHE

ANÁLISIS DE TEXTOS CONTINUOS**I. Lee atentamente los textos; luego, sobre la base de su contenido, desarrolla las indicaciones propuestas.****TEXTO 01****Gautama**

Ya el sol se había puesto entre el enredo del bosque sobre los ríos. Los niños de la ermita habían vuelto con el ganado y estaban sentados al fuego, oyendo a su maestro Gautama, cuando llegó un niño desconocido y lo saludó con flores y frutos. Luego, tras una profunda reverencia, le dijo con voz de pájaro:

- Señor Gautama, vengo a que me guíes por el sendero de la verdad. Me llamo Satyakama.
- Bendito seas -dijo el maestro- ¿Y de qué casta eres, hijo mío? Porque solo un brahmín puede aspirar a la suprema sabiduría.

- No sé de qué casta soy, maestro; pero voy a preguntárselo a mi madre.

Se despidió Satyakama, cruzó el río por lo más estrecho, y volvió a la choza de su madre, que estaba al fin de un arrenal, fuera de la aldea.

La lámpara iluminaba débilmente la puerta, la madre estaba fuera, de pie en la sombra, esperando la vuelta de su hijo.

Lo cogió contra su pecho, lo besó en la cabeza y le preguntó qué le había dicho el maestro.

- ¿Cómo se llama mi padre? -dijo el niño- Porque me ha dicho el señor Gautama que solo un brahmín puede aspirar a la suprema sabiduría.

La mujer bajó los ojos y le habló dulcemente:

- Cuando joven yo era pobre y conocí muchos amos. Solo puedo decirte que tú viniste a los brazos de tu madre Jabala, que no tuvo marido.

Los primeros rayos del sol ardían en la copa de los árboles de la ermita del bosque. Los niños estaban sentados ante su maestro, bajo un árbol viejo.

Llegó Satyakama, le hizo una profunda reverencia al maestro y se quedó de pie en silencio.

- Dime -le preguntó el maestro- ¿Sabes ya de qué casta eres?

- Señor -contestó Satyakama-, no sé. Mi madre me dijo: Yo conocí muchos amos cuando joven, y tú viniste a los brazos de tu madre Jabala, que no tuvo marido.

Entonces, se levantó un rumor como el zumbido iracundo de las abejas hostigadas en su colmena. Y los estudiantes murmuraban entre dientes de la desvergonzada insolencia del niño sin padre.

Pero el Maestro Gautama se levantó, trajo al niño con sus brazos hasta su pecho, y le dijo:

- Tú eres el mejor de todos los brahmines, hijo mío; porque tienes la herencia más noble, que es la de la verdad.

Rabindranat Tagore**NIVEL LITERAL****1. Son las características actitudinales de Satyakama.**

- A. Juguetón y atrevido
- B. Arriesgado y seguro
- C. Inteligente y triste
- D. Pobre y conformista
- E. Honesto y humilde

2. Es un hecho principal del cuento.

- A. Los niños escuchaban las enseñanzas de su maestro.
- B. El maestro era sabio y correcto.
- C. El niño escuchó indignado la confesión de la madre.
- D. La madre pensó que el maestro era prejuicioso.
- E. La madre le dijo al niño que no tuvo marido.

3. No es un hecho del cuento.

- A. Como muestra de admiración, el niño le llevó ofrendas a Gautama para pedirle que sea su maestro.
- B. Gautama le dijo a Satyakama que solo los brahmines podían ser sus discípulos.
- C. La madre se sorprendió y enojó ante la pregunta de su hijo sobre su origen.
- D. Los aprendices de Gautama criticaron a Satyakama por no tener padre.
- E. El maestro decidió guiar a Satyakama por tener el valor de la honestidad.

NIVEL INFERENCIAL**4. Del hecho "Los estudiantes murmuraban entre dientes de la desvergonzada insolencia del niño sin padre", indica la idea que se infiere de este.**

- A. Los niños juzgan los errores de los demás.
- B. No se debe criticar a los demás, sin conocer la verdad.
- C. Las mujeres, a veces, crían solas a sus hijos.
- D. Los prejuicios pueden provocar comentarios negativos.
- E. Los alumnos deben ser más sensibles ante la desgracia ajena.

NIVEL CRÍTICO

5. Explica, ¿por qué fue tan valiosa la respuesta del niño a Gautama?, ¿cómo aprovecharías esta enseñanza en tu vida diaria? Explica.

.....

.....

.....

TEXTO 02

Los malos vecinos

Había una vez un hombre que salió un día de su casa para ir al trabajo, y justo al pasar por delante de la puerta de la casa de su vecino, sin darse cuenta, se le cayó un papel importante. Su vecino, que miraba por la ventana en ese momento, vio caer el papel, y pensó:

- ¡Qué descarado, el señor, va y tira un papel para ensuciar mi puerta, disimulando descaradamente!

Pero en vez de decirle algo, planeó su venganza; por eso, por la noche, vació su papelería junto a la puerta del primer vecino. Este estaba mirando por la ventana en ese momento y cuando recogió los papeles encontró aquel papel tan importante que había perdido y que le había supuesto un problemón aquel día. Estaba roto en mil pedazos, pensó que su vecino no solo se lo había robado, sino que además lo había roto y tirado en la puerta de su casa. Pero no quiso decirle nada; así que, se puso a preparar su venganza. Esa noche llamó a una granja para hacer un pedido de diez cerdos y cien patos; además, pidió que los llevaran a la dirección de su vecino. Este, al día siguiente, tuvo un buen problema para tratar de librarse de los animales y sus malos olores. Pero, como estaba seguro de que aquello era idea de su vecino, en cuanto se deshizo de los cerdos comenzó a planear su represalia.

Y así, uno y otro siguieron fastidiándose mutuamente, cada vez más exageradamente, y de aquel simple papelito en la puerta llegaron a llamar a una banda de música, una sirena de bomberos, estrellar un camión contra la tapia, lanzar una lluvia de piedras contra los cristales, disparar un cañón del ejército y finalmente, una bomba que derrumbó las casas de los dos vecinos.

Ambos acabaron en el hospital y se pasaron una buena temporada compartiendo habitación. Al principio, no se dirigían la palabra; pero un día, cansados del silencio, comenzaron a hablar. Con el tiempo, se fueron haciendo amigos hasta que finalmente, un día, se atrevieron a hablar del incidente del papel. Entonces, se dieron cuenta de que todo había sido una coincidencia, que, si la primera vez hubieran hablado claramente, en lugar de juzgar las malas intenciones de su vecino, se habrían dado cuenta de que todo había ocurrido por casualidad.

Y así fue, hablando, como aquellos dos vecinos terminaron siendo amigos, lo que les fue de gran ayuda para recuperarse de sus heridas y reconstruir sus maltrechas casas.

Pedro Pablo Sacristán

<http://cuentosparadormir.com/infantiles/cuento/los-malos-vecinos>

NIVEL LITERAL

1. Las características actitudinales de los protagonistas son:

- A. Ambiciosos y avaros
- B. Celosos e inconstantes
- C. Inteligentes y aburridos
- D. Viciosos y sensibles
- E. Prejuiciosos y vengativos

2. Hecho principal del cuento:

- A. Un hombre arrojó un papel en la puerta de su vecino.
- B. Uno de los vecinos disculpó el accidente que tuvo su vecino.
- C. Por tercetos, ambos vecinos perdieron sus casas.
- D. La amistad es muy importante entre los vecinos.
- E. Un hombre creyó que su vecino actuaba en su contra; por eso decidió vengarse

NIVEL INFERENCIAL

3. Después de haber identificado el hecho principal en el ítem anterior, indica la idea que se infiere de este.

- A. Hay que disculpar los errores.
- B. La comprensión es esencial entre los vecinos.
- C. Es necesario hablar antes de actuar.
- D. No se debe actuar motivados por la cólera.
- E. Los prejuicios pueden provocar grandes problemas.

NIVEL CRÍTICO

4. Explica, ¿cómo puedes aprovechar el mensaje del cuento en tu vida diaria?

.....

.....

TEORÍA LITERARIA

II. Lee los siguientes enunciados; luego, coloca entre los paréntesis F si es falso o V si es verdadero cada enunciado propuesto.

1. La leyenda tiene la intención de explicar, a través de hechos fantásticos, el origen del mundo. (.....)
2. La novela se diferencia del cuento por poseer un nudo más complejo y varios personajes. (.....)
3. En los textos narrativos se incluyen descripciones. (.....)
4. El cuento se basa solo en hechos fantásticos. (.....)
5. El mito es una narración breve basada en hechos reales. (.....)

III. Lee el poema de José Watanabe y encierra la letra de la respuesta correcta de cada característica literaria.

Poema	Características literarias
<p align="center">La jovencita</p> <p><i>El algarrobo se inclina como una nube verde sobre la única bodega del pueblo. Detrás del mostrador humilde una grácil jovencita lleva nuestra mirada a un tiempo sin malicia. <u>Tiene el cabello recortado</u> <u>como un muchachito travieso. El próximo año</u> <u>tendrá la cabellera larga. El cuerpo</u> <u>sobrecoque de tan puntual y prolijo: cumplirá</u> <u>con el crecimiento de cada uno de sus cabellos</u> <u>y hará sonar una música</u> <u>menos inocente.</u> Mientras tanto, ella guarda sus negros mechones en un frasco de vidrio junto a los caramelos y gomas de menta. Eso es siniestro, pequeña. Tú, tan vivaz, hija del solcito que venimos a buscar, no deberías guardar nada muerto. No es justo para los que ahora te miramos como agüita de yerba para el desasosiego.</i></p> 	<p>1. El poeta:</p> <p>A. Describe escenarios y personajes con un lenguaje sencillo.</p> <p>B. Utiliza metáforas para resaltar las cualidades de un lugar de la sierra.</p> <p>C. Presenta costumbres y creencias de las comunidades.</p> <p>D. Narra experiencias vividas en su infancia y adolescencia.</p> <p>E. Emplea el idioma en sus poemas de una manera pulcra y correcta.</p> <hr/> <p>2. En los versos subrayados, la idea es:</p> <p>A. Las personas envejecen a medida que pasa el tiempo.</p> <p>B. Muchas veces, el amor llega de manera inesperada.</p> <p>C. Las golosinas son el mejor regalo para los niños.</p> <p>D. El paso del tiempo genera cambios físicos en las personas.</p> <p>E. No hay que dejar que el paso de los años nos provoque preocupación.</p> <hr/> <p>3. Reconoce tres figuras literarias que están presentes en el texto.</p> <hr/> <p>4. Enuncia el tema del poema.</p> <p>.....</p> <p>.....</p> <hr/> <p>5. Parafrasea el texto</p> <p>.....</p> <p>.....</p> <p>.....</p> <p>.....</p> <p>.....</p> <p>.....</p>

RAZONAMIENTO VERBAL

IV. Relaciona las palabras presentadas con su significado lexical, colocando el número correspondiente en los recuadros.

1.	NEOLOGISMO		Sitio poblado de álamos.
2.	POLÍGLOTA		Dicho de una persona: Versada en varias lenguas.
3.	CRONOLOGÍA		Voz del toro y de otros animales salvajes.
4.	SEMÁNTICO		Relativo a un mismo género.
5.	HOMOGÉNEO		Ciencia que tiene por objeto determinar el orden y fechas de los sucesos históricos.
6.	POLIEDRO		Dicho de un animal: Que se alimenta de toda clase de sustancias orgánicas
7.	TUMULTO		Vocablo, acepción o giro nuevo en una lengua.
8.	BRAMIDO		Motín, confusión, alboroto producido por una multitud.
9.	OMNÍVORO		Sólido limitado por superficies planas.
10.	ALAMEDA		Perteneciente o relativo a la significación de las palabras.

V. Escribe, en los espacios punteados, el SIGNIFICADO CONTEXTUAL de la palabra subrayada en los textos propuestos.

- Los fumadores son dos veces más propensos a dejar el **hábito** de fumar si reciben mensajes de texto que los ayuden a cumplir con su objetivo de liberarse del humo.
.....
- El léxico de una lengua no es fijo ni invariable, lo cual es lógico, ya que se transforma y metamorfosea como la sociedad.
.....

VI. Lee el texto de La cultura Moche. Luego, subraya con color azul la idea principal y con color rojo, las ideas secundarias.

La cultura Moche

La cultura Moche entró en progresiva decadencia y luego colapsó. Esto se debió a diversas razones. En primer lugar, se dio un periodo de sequías prolongadas, inundaciones y lluvias de arena como consecuencia del fenómeno de El Niño. En segundo lugar, empezaron a producirse conflictos al interior de la sociedad. Los habitantes empezaron a desconfiar de la capacidad de sus líderes de comunicarse con los dioses, pues no podían convencerlos de que dejaran de mandar catástrofes naturales. Y, en tercer lugar, se introdujeron ideas novedosas en el arte y la religión que cambiaron las rígidas normas existentes.

VII. Lee los ejercicios propuestos y encierra la letra de la alternativa que se relacione con la pareja base.

1. EMPRESA : GERENTE ::	2. EXTENUADO : FUERZA ::	3. CABALLERO : VANIDAD::
A. justicia : juez B. congreso : congresista C. ministerio : funcionario D. barco : capitán E. seguidor : líder	A. ignorante : respeto B. empobrecido : recurso C. destacado : celebridad D. obnubilado : juicio E. deprimido : ánimo	A. Bolsalegre : tristeza B. Julieta : compasión C. Merlín : sabiduría D. Rebeca : pereza E. Cristóbal : deshonestidad
4. CAMALEÓN : SUSTANTIVO::	5. DROGADICCIÓN : CIRROSIS::	6. CHAN CHAN : LA LIBERTAD::
A. alegre : adjetivo B. conector : sin embargo C. inteligencia : verbo D. artículo : los E. pronombre : ellos	A. comida : anorexia B. asma : pulmonía C. cólico : estómago D. verdura : anemia E. gula : pecado	A. Señor de Sipán: Lambayeque B. Santa Rosa : Lima C. Machu Picchu : Cuzco D. Cristo de Corcovado : Brasil E. Gran Muralla : China

PRODUCCIÓN DE TEXTOS

VIII. Redacta un texto expositivo de estructura completa a partir de los conocimientos que tengas sobre la cultura Chimú.

Escribe textos con coherencia y cohesión de acuerdo a un tema.	Maneja correctamente la estructura textual.	Escribe con letra legible y uniforme.	Utiliza correctamente grafías y tildes.	Utiliza correctamente los signos de puntuación.	Muestra orden y limpieza en la elaboración de sus trabajos.	TOTAL
0-5	0-3	0-2	0-5	0-3	0-2	

.....

.....

.....

.....

.....

.....

.....

.....

.....

.....

.....

.....

.....

.....

.....

.....

.....

.....

.....

.....

.....



I. Lee atentamente el texto presentado. Luego, contesta lo que se te solicita. No olvides de aplicar estrategias de comprensión lectora.

La violencia

Todos los seres humanos vivimos situaciones conflictivas y, muchas veces, cometemos actos violentos. También somos agredidos muchas más veces de las que podemos recordar. No solo hemos participado de un intercambio de violencia con algún desconocido, además lo hemos hecho con compañeros y compañeras y miembros de la familia. Un ejemplo de agresiones muy frecuentes entre miembros de la familia es castigar a un niño o niña con el uso de la fuerza física y la agresión verbal.

La violencia tiene que ver con la utilización de la fuerza física o de la coacción psíquica o moral por parte de un individuo o grupo de sujetos en contra de sí mismo, de objetos, o de otra persona o grupo de personas víctimas por lo que constituye una amenaza o negación de las condiciones de posibilidad de realización de la vida y de la supervivencia. La salud no solo es la ausencia de enfermedades, sino el estado de completo bienestar biológico, psicológico y social. Si existe la violencia como factor actuante sobre los tres aspectos anteriores, es evidente que afecta el estado de salud.

La complejidad de la violencia no debe ser un pretexto para la pasividad frente a ella; con el simple hecho de menospreciar a los menores, regañarlos y hasta castigarlos duramente, se imprime en ellos una dosis diaria de violencia que los convertirá en el futuro en adultos violentos. No por negar o no reconocer la violencia, dejará de existir.

Las generaciones futuras tienen el derecho a crecer en un mundo de paz, sin violencia; lo que se traducirá, a largo plazo, en salud y bienestar para todos. Se trata de una realidad social históricamente transformable y controlable que requiere de esfuerzos a todos los niveles y en varios campos; por lo que los autores se proponen profundizar en el estudio de la violencia, y en particular, de la violencia intrafamiliar; estudiar la posible relación entre el consumo de alcohol y las manifestaciones de violencia y contribuir al mejoramiento de la calidad de vida.

http://www.mujerysalud.gob.mx/mys/doc_pdf/folleto.pdf

http://scielo.sld.cu/scielo.php?pid=S0864-21251998000600005&script=sci_arttext

NIVEL LITERAL

1. De acuerdo al texto, la violencia significa:

- A. Violar los derechos humanos.
- B. Atentar contra el bienestar físico, psicológico y social.
- C. Ir en contra de la realidad social.
- D. Aceptar que los conflictos no pueden solucionarse.
- E. Olvidar que los derechos de uno acaban donde empiezan los de los demás.

NIVEL INFERENCIAL

2. La idea principal del tercer párrafo es:

- A. La violencia siempre estará presente en la vida del ser humano.
- B. No hay que aceptar la violencia por ningún motivo.
- C. Los niños se forman en hogares violentos.
- D. Debemos tomar conciencia de que la violencia genera más violencia.
- E. Los padres deben ser violentos con sus hijos.

3. El subtema desarrollado en el primer párrafo es:

- A. Padres violentos
- B. Clases
- C. Introducción
- D. Los derechos humanos
- E. La violencia y la paz

NIVEL CRÍTICO

4. ¿Qué opinas sobre la violencia que se da de padres a hijos (violencia familia)? ¿Qué se puede hacer para erradicar este problema?

Yo opino que _____

Para solucionar este problema:

Solución 1: _____

Solución 2: _____

ANÁLISIS DE TEXTOS DISCONTINUOS

II. Observa la imagen y anota su significado denotativo y connotativo.



SIGNIFICADO DENOTATIVO	SIGNIFICADO CONNOTATIVO

TEORÍA LITERARIA

III. Lee los textos propuestos e indica a qué género literario pertenece cada uno. Luego, en los recuadros de la parte inferior, escribe dos características propias de cada género.

TEXTO 1	TEXTO 2	TEXTO 3
<p>Madre: ¿Traes el reloj? Novio: Sí. Madre: Tenemos que volver a tiempo. ¡Qué lejos vive esta gente! Novio: Pero estas tierras son buenas. Madre: Buenas; pero demasiado solas. Cuatro horas de camino y ni una casa ni un árbol. Novio: Son los secanos. Madre: Tu padre los hubiera cubierto de árboles. Novio: ¿Sin agua?</p>	<p>Es la mañana llena de tempestad en el corazón del verano. Como pañuelos blancos de adiós viajan las nubes, el viento las sacude con sus viajeras manos. Innumerable corazón del viento latiendo sobre nuestro silencio enamorado.</p>	<p>Era yo niño aún cuando me alejaron de la casa paterna para que diera principio a mis estudios en el colegio del doctor Lorenzo María Lleras, establecido en Bogotá hacía pocos años, y famoso en toda la República por aquel tiempo. En la noche víspera de mi viaje, después de la velada, entró a mi cuarto una de mis hermanas, y sin decirme una sola palabra cariñosa, porque los sollozos le embargaban la voz, cortó de mi cabeza unos cabellos: cuando salió, habían rodado por mi cuello algunas lágrimas tuyas.</p>
<p>Género literario: Características</p>	<p>Género literario: Características</p>	<p>Género literario: Características</p>

PRODUCCIÓN DE TEXTOS

IV. Elabora una historieta sobre el tema “Importancia de la armonía en el aula”. Ten en cuenta los indicadores mencionados.

Presentación	Caligrafía	Ortografía		Recursos	Contenido
		Letras , tildes	Puntuación		
0-2	0-2	0-5	0-3	0-6	0-2

.....

ANÁLISIS DE TEXTOS CONTINUOS

I. Lee atentamente el texto presentado. Luego, contesta lo que se te solicita. No olvides de aplicar estrategias de comprensión lectora.

El tercer mundo como basurero

<<Esta exportación empezó enviando ropa usada; ahora abarca una diversidad de productos desechados en el mundo desarrollado, incluidos los muy dañinos.

La ropa usada sigue siendo exportada masivamente a América Latina y a otras regiones. En algunos casos, viaja como donación de prendas que, desde cierto nivel de vida, en Estados Unidos y Europa son descartadas por su desgaste o por haber pasado de moda. En vez de que ocupen inútilmente espacio en la casa, su entrega a alguna organización humanitaria permite al donante ese pequeño lujo de ejercer la caridad. Puede que, una vez en el lugar de destino, no sean repartidas gratuitamente sino vendidas -el donante no lo sabe- pero, regaladas o no, el propósito principal se ha cumplido: lo desechado ya está lejos, en algún país del sur, y viste a quienes no pueden pagar por un producto nuevo.

Las medicinas de vencimiento muy próximo adquieren, en este tráfico, un sabor siniestro. Laboratorios del mundo desarrollado 'donan' a los países pobres -de África, en especial- medicinas a punto de caducar, cuyo valor descargan así en sus declaraciones de impuestos. Vendidas o regaladas en el país 'beneficiario de la ayuda', no son perjudiciales en el mejor de los casos y producen daños en el peor. Además del beneficio tributario, el laboratorio donante ha resuelto el problema -y se ha ahorrado el costo- de eliminar un producto indeseable.

El uso del tercer mundo como basurero de los países desarrollados permite a estos no asumir los costos ni la responsabilidad por niveles de consumo que, de no mediar estas exportaciones insanas, resultarían insostenibles. El traslado sistemático de bienes que resultan inútiles y de deshechos incómodos o peligrosos hace posible desentenderse de las consecuencias de un modelo de consumo que, siempre en busca de productos nuevos, renueva constantemente la oferta, a menudo de manera frívola.

El gobierno de un país dado puede poner límites y controles para evitar los peores efectos de este comercio vergonzoso. Sin embargo, siempre habrá otro país dispuesto a recibir la basura de la que el mundo desarrollado busca deshacerse. África resulta, desde este ángulo, el continente más disponible como destino. Pero, la pobreza de la población y la corrupción de los gobiernos hacen que en todo el tercer mundo las fronteras permanezcan abiertas a la basura del primero>>.

Recuperado el 2 de noviembre de 2013

<http://ahora-hurroca.blogspot.com/2007/11/el-tercer-mundo-como-basureroescribe.html>

NIVEL LITERAL

1. Según el autor del texto, ¿por qué los países desarrollados emplean a las naciones del tercer mundo como basureros? **Porque:**

- A. Quieren proteger su medio ambiente.
- B. Son unos deshonestos y abusivos.
- C. Quieren renovar sus productos desechando los anteriores sin mayores costos.
- D. No hay límites ni controles en el consumo de diversos productos.
- E. Consideran que benefician a los países del tercer mundo.

NIVEL INFERENCIAL

2. Del segundo párrafo se infiere la idea:

- A. La ropa usada es donada porque pasó de moda.
- B. La ropa donada, a veces, se comercializa y no se entrega a sus destinatarios.
- C. Los donadores conocen a quiénes se les entrega la ropa enviada.
- D. Los beneficiados con la ropa usada son personas de distinta clase social.
- E. La entrega de la ropa usada debe ser normada.

3. Del quinto párrafo se infiere la idea:

- A. Los productos donados deben ser entregados a la gente más pobre.
- B. Hay países muy pobres que permiten el ingreso de productos peligrosos.
- C. Es necesario tomar conciencia de los problemas que generan algunos productos donados.
- D. Los donativos deben pasar por una evaluación antes de entregarse a sus destinatarios.
- E. Las normas deben ser rigurosas para evitar el ingreso de productos al país.

NIVEL CRÍTICO

4. ¿Te parece honesto que se comercialicen productos importados deficientes o dañinos en los países más pobres? Justifica tu respuesta con dos argumentos.

Primer argumento: _____

Segundo argumento: _____

TEORÍA LITERARIA

II. Lee los textos propuestos y, de acuerdo con su contenido, resuelve las actividades planteadas.

1. En los recuadros, escribe si el texto se presenta en prosa o en verso. Además, identifica tres figuras literarias en el primer texto y una, en el segundo.

<p align="center">La primavera besaba</p> <p><i>La primavera besaba suavemente la arboleda, y el verde nuevo brotaba como una verde humareda.</i></p> <p><i>Las nubes iban pasando sobre el campo juvenil... Yo vi en las hojas temblando las frescas lluvias de abril. (...)</i></p> <p align="right">Antonio Machado</p>
<p>.....</p> <p><i>(...) Ante sus ojos había un espectáculo maravilloso. A través de una brecha del muro habían entrado los niños, y se habían trepado a los árboles. En cada árbol había un niño, y los árboles estaban tan felices de tenerlos nuevamente con ellos, que se habían cubierto de flores y balanceaban suavemente sus ramas sobre sus cabecitas infantiles. Los pájaros revoloteaban cantando alrededor de ellos, y los pequeños reían. Era realmente un espectáculo muy bello. (...)</i></p> <p align="right">Óscar Wilde. El gigante egoísta</p>
<p>.....</p>

2. En base a los textos anteriores, coloca V si es verdadera o F si es falsa la información propuesta.

- A. El texto B presenta una forma especial en su expresión. (_____)
- B. El texto A posee ritmo y musicalidad. (_____)
- C. El texto B no posee un ritmo especial. (_____)
- D. El texto A se presenta en la forma habitual de escribir. (_____)
- E. Ambos textos son no literarios. (_____)

3. Completa el siguiente cuadro con dos diferencias entre la prosa y el verso.

PROSA	VERSO
1. _____ _____	1. _____ _____
2. _____ _____	2. _____ _____

RAZONAMIENTO VERBAL

III. Desarrolla los ítems planteados en forma clara, precisa y ordenada.

1. Relaciona las palabras presentadas con su significado lexical, colocando la letra correspondiente en los recuadros.

OBSOLETO		B	tr. Abolir, anular una norma establecida, como una ley o una costumbre.
ESCÉPTICO		C	tr. Publicar formalmente una ley u otra disposición de la autoridad, a fin de que sea cumplida y hecha cumplir como obligatoria.
REFUTAR		D	tr. Estropear, menoscabar, poner en inferior condición algo.
DEROGAR		E	adj. Acreditado de cierto y positivo por los caracteres, requisitos o circunstancias que en ello concurren.
SOBERBIA		M	adj. Anticuado, inadecuado a las circunstancias actuales.
PROMULGAR		N	f. Espacio grande de tierra llana labrantía.
DETERIORAR		P	adj. Que no cree o afecta no creer.
CAMPIÑA		T	tr. Contradecir, rebatir, impugnar con argumentos o razones lo que otros dicen.
AUTÉNTICO		Q	adj. Favorable para que algo se logre.
PROPICIO		U	f. Altivez y apetito desordenado de ser preferido a otros.

2. Lee atentamente las oraciones propuestas. Luego, escribe el significado contextual del término subrayado.

- Actuó con dignidad.

- Es un dignatario reconocido de Perú.

3. Lee las oraciones y cambia las palabras subrayadas por sus ANTÓNIMOS seleccionándolos de las propuestas en el recuadro.

POSTERIOR	DESAGRADO	ABUNDANCIA	QUITA	CAOS	OLVIDAR	AMPLIAR
------------------	------------------	-------------------	--------------	-------------	----------------	----------------

- Siempre pone () entusiasmo en los trabajos que realiza.
- En el aula, prevalece el orden ()
- Hay escasez () de trabajadores en el país.
- Se debe recordar () solo los hechos tristes.

4. Encierra, con una circunferencia, la alternativa que presenta el ANTÓNIMO de las palabras subrayadas en las oraciones.

<p>1. Los docentes <u>respaldaron</u> la decisión de los estudiantes.</p> <p>A. apoyaron B. refutaron C. rectificaron D. refrendaron E. desaprobaron</p>	<p>2. Tendrá un castigo <u>severo</u>.</p> <p>A. adecuado B. sincero C. delgado D. fino E. leve</p>
<p>3. Se le declaró <u>vencedor</u>.</p> <p>A. inteligente B. valiente C. ganador D. perdedor E. fracaso</p>	<p>4. Es muy <u>escéptico</u>.</p> <p>A. crédulo B. falso C. incrédulo D. incorregible E. ignorante</p>

ANÁLISIS DE TEXTOS DISCONTINUOS

IV. Lee los afiches propuestos; luego resuelve las actividades planteadas.

Afiche 1

INSTITUTO SUPERIOR TECNOLÓGICO
SISE

**MIRA MÁS ALLÁ DE
LOS LÍMITES**

Lleva los negocios más allá de
lo que te imaginas
estudiando
la carrera profesional de:

**GESTIÓN EMPRESARIAL
MARKETING**

INICIO DE CARRERAS
12 de FEBRERO

HORARIOS
mañana 09:00 am - 12:30 pm
noche 07:00 pm - 10:30 pm

SISE Larco: 2934478

- Utilizando flechas, reconoce la estructura del texto.
- ¿Qué tipo de afiche es: publicitario o propagandístico? Justifica tu respuesta con dos razones.

Afiche 2

**Solo plántate por un mundo
mejor.**

**5 de
Junio**

Celébralo en el SENA
El 10 de junio a partir
De las 08:00 a.m.

SENA

**Día del
Medio Ambiente**

Centro Agroecológico y Empresarial - Regional Cundinamarca

- ¿Cuáles son los datos informativos?
- ¿A qué público estará dirigido el afiche? Explica.
- ¿Cuál es el propósito del afiche? Fundamenta tu respuesta.

- I. Lee detenidamente los textos propuestos, aplicando el subrayado como técnica de comprensión lectora. Luego, resuelve lo ítems planteados.

TEXTO 01**Sube nivel del mar debido a la contaminación ambiental**

<<WASHINGTON, ESTADOS UNIDOS (22/FEB/2016). Los niveles del mar están subiendo mucho más rápidamente que en los últimos dos mil ochocientos años y la tendencia se acelera debido al calentamiento global causado por los seres humanos, según nuevos estudios.

Un equipo internacional de científicos excavó en dos docenas de sitios en distintas partes del mundo para registrar las alzas y bajas de los mares a lo largo de siglos y milenios. Hasta la década de 1880 y la industrialización mundial, las alzas más pronunciadas fueron de tres a cuatro centímetros (uno a 1.5 pulgadas) por siglo. Durante ese tiempo, el nivel de los mares no oscilaba mucho más que cinco centímetros (tres pulgadas) en comparación con el promedio de dos mil años.

Pero en el siglo XX el nivel de los mares subió 14 centímetros (5.5 pulgadas). Desde 1993 la tasa ha aumentado a hasta 30 centímetros (un pie) por siglo. Y dos estudios publicados el lunes en la revista *Proceedings de la Academia Nacional de Ciencias*, dicen que para el 2100, los océanos subirán entre 28 y 131 centímetros (11 a 52 pulgadas), dependiendo de cuántos gases de efecto invernadero emitan las industrias.

"No hay duda de que el siglo XX es el más **acelerado**", comentó Bob Kopp, profesor de ciencias terrestres y planetarias en Rutgers, autor central del estudio que revisó el nivel de los mares en los tres últimos milenios. "Se debe al aumento de las temperaturas en el siglo XX impulsado por el uso de combustibles fósiles".

Para determinar el nivel de los mares en el pasado y las tasas de alzas o bajas, los científicos se abocaron a una "historia detectivesca geológica", afirmó el coautor del estudio Ben Horton.

Cuando Kopp y sus colegas trazaron los cambios en el nivel de los mares a lo largo de los siglos "se remontaron tres mil años, aunque no están tan seguros en los 200 primeros" comprobaron que el nivel de los mares estuvo en baja hasta la era industrial.

El aumento en el nivel de los mares en el siglo XX se debe principalmente a la acción de los seres humanos, dijeron los autores del estudio. Otro estudio todavía no publicado de Kopp y colaboradores halló que, desde 1950, unos dos tercios de las inundaciones costeras en 27 sitios en Estados Unidos tienen el sello del calentamiento global causado por el hombre.

Y si el nivel de los mares sigue subiendo, como se proyecta, otros 28 centímetros (18 pulgadas) de aumento causará grandes problemas y gastos, dijo el coautor del estudio Stefan Rahmstorf, del instituto de Postdam para la Investigación sobre el Impacto Climático en Alemania>>.

Recuperado el 30 de marzo de 2016

<http://www.informador.com.mx/tecnologia/2016/646270/6/sube-nivel-del-mar-debido-al-calentamiento-global.htm>

NIVEL LITERAL

1. El nivel del mar está aumentando debido a:

- A. las investigaciones realizadas por un grupo de científicos.
- B. la contaminación ambiental originada por el ser humano.
- C. los desastres naturales que se dan cada cierto tiempo.
- D. la revolución industrial de los países desarrollados.
- E. las lluvias y su incremento acelerado a través de estos dos mil años.

2. El sinónimo contextual de la palabra destacada es:

- A. Atropellado
- B. continuado
- C. apurado
- D. prolongado
- E. apresurado

NIVEL INFERENCIAL

3. Es la idea que se infiere del cuarto párrafo.

- A. Hay problemas que empeoran con el transcurrir del tiempo debido al descuido de las personas.
- B. Algunas veces, el ser humano es consciente de sus errores y decide darles solución.
- C. No es bueno que el hombre contamine su mundo porque se puede quedar sin hogar.
- D. El ser humano es el propio constructor de sus beneficios o desgracias.
- E. No debemos quemar residuos fósiles y así evitar el incremento del agua de los mares.

4. **Es el mensaje que se puede extraer del texto.**

- A. Debemos tomar conciencia de nuestro comportamiento en contra de la naturaleza y plantar más árboles.
- B. Tenemos que asumir la responsabilidad de nuestros actos y pensar en posibles soluciones para detener la contaminación ambiental.
- C. Hay que pensar en los animales marinos que son quienes más sufren el incremento de las aguas de los mares y océanos.
- D. No debemos echar residuos ni contaminar los océanos, porque la vida de los mares está próxima a extinguirse.
- E. No hay que utilizar residuos fósiles, ya que aceleramos la aparición de desastres naturales que afectan al medio ambiente.

NIVEL CRÍTICO

5. **Menciona tres alternativas de solución para mejorar el problema planteado en el texto. Fundamenta tus respuestas con un argumento.**

- A. _____

- B. _____

- C. _____

TEXTO 02

La leyenda del fuego y del jaguar

Hace mucho tiempo, los animales no tenían fuego, tenían que comer su comida cruda y en invierno pasaban bastante frío. El león y el elefante compartían la misma cueva. Al oso no le bastaba ser como era. El jaguar en esos tiempos no tenía sus manchas, sino que era todo amarillo. Un día que estaba descansando en una montaña alta, al sol le dieron lástima los animalitos y le gritó al jaguar:
- Jaguar, te voy a dar una cosa que usarás y compartirás con los demás animales. Es fuego. Levanta esa rama que tiene pasto seco, que yo te lo enciendo. El jaguar agradecido corrió con la antorcha encendida, pero no fue a donde estaban los demás animales, sino al bosque y con una risa le dijo al sol:
- Ahora sí comeré todo asado y muy rico y en invierno no pasare más frío. Y los demás no les daré nada, afín de cuentas todo lo hice yo.
El sol se enfureció por su actitud y le lanzó unos rayos que le provocaron unas quemaduras en el cuerpo del animal y que luego nunca se pudieron borrar.



NIVEL LITERAL

1. **Subraya los hechos principales del texto y, con ellos, elabora el respectivo resumen.**
2. **Son personajes principales del texto La leyenda del fuego y del jaguar.**
 - A. El jaguar y el sol
 - B. Los animales del bosque
 - C. El oso y el elefante
 - D. El león y el elefante
 - E. Solo el jaguar
3. **Es una idea que se infiere del hecho subrayado.**
 - A. Las personas detestan consumir alimentos fríos.
 - B. Muchas veces, la ingratitud genera decepción.
 - C. Hay acciones negativas que provocan mucho enojo.
 - D. No todas las personas agradecen la ayuda recibida.
 - E. Muchos castigos se otorgan de manera injusta.

Trastornos alimentarios

A muchos niños, pero mucho más a los adolescentes, les preocupa su aspecto físico y algunos se sienten acomplejados con su cuerpo. Esto es particularmente cierto durante la pubertad, momento en que experimentan importantes cambios corporales y en que han de afrontar nuevas presiones sociales.

Desafortunadamente en una proporción de niños y adolescentes que va en aumento, esta preocupación puede llegar a convertirse en una obsesión que, a su vez, puede derivar en un desorden alimenticio. Los trastornos del apetito, como la anorexia nerviosa y la bulimia nerviosa, provocan **fluctuaciones** exageradas en el peso, interfieren en la vida diaria y pueden repercutir negativa y permanentemente sobre la salud.

Los trastornos alimentarios son tan comunes en muchos países a nivel mundial, principalmente en los desarrollados, por ejemplo en los Estados Unidos que 1 o 2 de cada 100 estudiantes padece uno de estos trastornos. Cada año, miles de adolescentes padecen perturbaciones alimenticias o problemas de peso, de alimentación o con la imagen corporal.

Un trastorno alimentario implica más que simplemente hacer dieta para perder peso o hacer ejercicio todos los días. Se trata de comportamientos alimentarios extremos: Por ejemplo, dietas que nunca terminan y que, gradualmente, se vuelven más estrictas. También guarda relación con personas que no salen con amigos porque creen que es más importante salir a correr para contrarrestar el dulce que comieron más temprano.

Los padres juegan un rol muy importante en todo esto, ya que pueden contribuir a que sus hijos no desarrollen este tipo de trastornos favoreciendo el desarrollo de autoestima y actitudes sanas en relación a la alimentación y el aspecto físico. Si le preocupa la posibilidad de que su hijo pueda estar desarrollando un desorden alimenticio, es importante que intervenga y busque atención médica adecuada.

Recuperado el 26/08/2016

<http://kidshealth.org/es/teens/eat-disorder-esp.html>

NIVEL LITERAL

1. Son tipos de trastorno alimentario.

- A. La bulimia y la anorexia nerviosas
- B. Las dietas estrictas interminables
- C. El alejamiento de los amigos y la escuela
- D. El consumo de golosinas y comida chatarra
- E. Las comilonas excesivas y el vómito

2. El sinónimo contextual de la palabra destacada es:

- A. pérdidas
- B. modificaciones
- C. transformaciones
- D. novedades
- E. crecimientos

NIVEL INFERENCIAL

3. Es la idea que se infiere del primer párrafo.

- A. Hay padres que están pendientes de los problemas de sus hijos y buscan las soluciones.
- B. Las enfermedades corporales generan siempre las enfermedades emocionales.
- C. No todos los seres humanos viven preocupados por los mismos temas.
- D. La apariencia física puede inquietar a muchas personas en un momento determinado de su vida.
- E. Hay situaciones que son difíciles de controlar y generan mucha ansiedad en las personas.

4. Es el mensaje que se puede extraer del texto.

- A. Debemos asistir a charlas informativas donde nos guíen por el camino correcto y no terminemos siendo esclavos de las dietas extremas.
- B. Debemos acudir al nutricionista y al psicólogo para que nos ayuden con nuestra alimentación y no suframos de algún trastorno alimenticio.
- C. Debemos alimentarnos de manera correcta y hacer ejercicios diarios para mantener un equilibrio entre la mente y el cuerpo.
- D. Hay que conversar con nuestros padres sobre nuestros problemas, ya que ellos son quienes mejor nos pueden ayudar.
- E. Tenemos que conocer detalladamente sobre los trastornos alimenticios para sentirnos seguros de nuestro cuerpo y no atentar contra él.

NIVEL CRÍTICO

5. Menciona dos razones por las que es importante mantener una vida saludable: Hacer ejercicios y consumir alimentos nutritivos. Fundamenta tus respuestas.

A. _____

B. _____

PRODUCCIÓN DE TEXTOS

II. Redacta un **texto expositivo** sobre la región La Libertad, en diez líneas como mínimo y doce como máximo.

Escibe textos con coherencia y cohesión de acuerdo a un tema.	Maneja correctamente la estructura textual.	Escibe con letra legible y uniforme.	Utiliza correctamente grafías y tildes.	Utiliza correctamente los signos de puntuación.	Muestra orden y limpieza en la elaboración de sus trabajos.	TOTAL
0-5	0-3	0-2	0-5	0-3	0-2	

.....

.....

.....

.....

.....

.....

.....

.....

.....

.....

.....

.....





Inventario de actividades de Inglés (nivel: STARTER) (Apoyo a la recuperación académica 2017)

Estimado estudiante:

Te proponemos el presente inventario de actividades como un recurso de apoyo para el proceso de recuperación académica que debes seguir durante el mes de enero de 2018. Te pedimos tener presente, respecto al inventario, lo siguiente:

- Ha sido elaborado de acuerdo con un temario anual, el cual considera los cuatro bimestres (25 % c/u).
- Las actividades que se presenta en él han sido tomadas de documentos de trabajo, libros del año escolar 2017 y de otras fuentes, pero que se ajustan a los contenidos del temario anual.
- Ha sido dosificado para ser desarrollado en cuatro semanas, de lunes a viernes, destinando para ello una hora diaria aproximadamente.
- El estudiante debe imprimir los documentos que serán desarrollados, archivados y presentados en un fólter manila tamaño oficio (incluir carátula), el mismo que será revisado y evaluado por los docentes responsables de la evaluación de recuperación, asignándole un peso de 25 % en el resultado final de la recuperación como “evaluación de portafolio”. De hecho, si no lo presentases desarrollado, se te asignará la nota mínima en evaluación de portafolio.
- Si los estudiantes requiriesen presentarse a la segunda oportunidad, podrán mejorar y volver a presentarlo desarrollado, prevaleciendo, en este caso, la segunda calificación. Si no lo hiciesen, mantendrán la calificación obtenida en la primera ocasión.
- En la tabla de control diario, el padre de familia debe firmar para apoyar y controlar el avance diario del estudiante en su desarrollo.
- No hemos incluido una calendarización específica para su desarrollo (fechas de inicio y fin), asumiendo que cada estudiante lo hará en coordinación con sus padres, considerando la realidad particular y los planes de la familia. En todo caso, el trabajo ha sido previsto para cuatro semanas.
- La primera oportunidad de evaluación será a fines de enero. La presentación del portafolio (inventario desarrollado) es obligatoria desde la primera oportunidad de evaluación.

Semana 1

Bimestre 1

Unit 2

Grammar: to be (negative, singular and plural); to be (questions and short answers); object pronouns

Vocabulary: adjectives to describe feelings; positive and negative adjectives.

Semana 2

Bimestre 2

Unit 5

Grammar: present simple: affirmative, negative and interrogative forms; adverbs of frequency;

Vocabulary: free-time activities, gadgets

Semana 3

Bimestre 3

Unit 8

Grammar: Present continuous: affirmative, negative and interrogative forms; like / don't like + -ING.

Vocabulary: clothes.

Semana 4**Bimestre 4****Unit 10****Grammar:** Past simple: BE (was / wasn't, were/ weren't; Was he? / Were you ...?)

Past simple: Regular and irregular verbs: affirmative and negative forms.

Vocabulary: time expressions: past; the weather.

	Tabla de firmas del padre de familia de control diario				
	Lunes 1 de enero	Martes 2 de enero	Miércoles 3 de enero	Jueves 4 de enero	Viernes 5 de enero
Semana 1					
	Lunes 8 de enero	Martes 9 de enero	Miércoles 10 de enero	Jueves 11 de enero	Viernes 12 de enero
Semana 2					
	Lunes 15 de enero	Martes 16 de enero	Miércoles 17 de enero	Jueves 18 de enero	Viernes 19 de enero
Semana 3					
	Lunes 22 de enero	Martes 23 de enero	Miércoles 24 de enero	Jueves 25 de enero	Viernes 26 de enero
Semana 4					

ANEXOS**Anexo 1_bim 1****Anexo 2_bim 2****Anexo 3_bim 3****Anexo 4_bim 4**

Bimestre 1

WEEK 1

Unit 2

Grammar: to be (negative, singular and plural); to be (questions and short answers); object pronouns

Vocabulary: adjectives to describe feelings; positive and negative adjectives.

Monday

1 Complete the words.



0 a ngry



1 s _____



2 t _____



3 h _____



4 h _____



5 w _____

2 Complete the sentences with the words in the list.

sad | bored | excited | tired | cold | hungry

0 Anna isn't happy. She's sad.

3 The weather is terrible today. I'm really _____.

1 I want some food. I'm really _____.

4 I'm _____. I want to sleep.

2 It's my birthday tomorrow. I'm so _____!

5 I'm _____. There's nothing to do.

3 Complete the sentences with the correct negative form of to be. Use contractions.

0 Sandra is from New York. She isn't from Chicago.

1 I _____ hungry.

2 We _____ thirsty, thank you.

3 You _____ late. It's only one o'clock.

4 Rio de Janeiro is in Brazil. It _____ in Mexico.

5 I don't like James and Suzanne. They _____ very friendly.

I. Write the words in the correct order.

sister / Bart's / Lisa. / is

Lisa is Bart's sister.

1 playing / saxophone. / hobby / Lisa's / is / the

2 one / old? / Is / Maggie / year

3 perfect / not / a / father. / Homer / is

4 the Principal's / Bart / is / office. / in

II. Write complete answers.

0. Where are you from?

I'm from Mexico.

1. What are you good at?

2. What are you interested in?

3. What can you do?

4. When is your birthday?

III. Circle the correct answer.

0. I'm to Japan / of Japan / from Japan.

1. I'm good at swimming / swimming / to swim.

2. I'm interested soccer / at soccer / in soccer.

3. I can to dance / dancing / dance.

4. Look at the / to the / the blackboard.

I. Read the text. Write true (T) or false (F).

Snowboarding's a multi-million-dollar industry. It's a new sport, but it's very popular in the USA and a big attraction in Europe. In the USA, you can snowboard at special snow parks in ski areas. People who are good at skiing, surfing and skateboarding are often good at snowboarding, too. Good balance, coordination and energy are necessary for all these sports. Imagination and creativity are important qualities for snowboarders, too.

Snowboarding's an official Olympic sport for men and for women. Individual talent is important, but a good snowboard's very important, too. It can be an expensive sport: the price of everything, including the snowboard, can be hundreds of dollars! It can also be dangerous.

- 0. Snowboarding's popular in Europe. ____
- 1 There are usually parks for snowboarding in ski areas in the USA. ____
- 2 Good snowboarders have good balance and imagination. ____
- 3 Only men can win Olympic medals in snowboarding. ____
- 4 Snowboarding isn't a cheap sport. ____
- 5 It's a very safe sport. ____

II. Write the correct pronouns in the spaces.

she - him - it - them - I - him

- a) _____ likes John. John likes her.
- b) _____ go to secondary school.
- c) I watch cartoons on TV. I love _____.
- d) Paris is a big city and _____ is beautiful!
- e) He's a good player. I play with _____.

III. Read the text and replace the underlined words with he, we, they or she.

- a) J.K.Rowling is a woman. _____ writes the Harry Potter books.
- b) Harry Potter is a special boy. _____ is a magician.
- c) Harry's friends are fantastic. _____ play Quidditch.
- d) My brother and I like all the books. _____ love the adventures!

IV. Write the correct object pronoun in the spaces.

me her them us it them her

- a) I work with Emma, and she works with ____.
- b) My parents know my boyfriend, and he knows _____.
- c) Sheila talks to Albert, and he listens to _____.
- d) My mom loves me, and I love _____.
- e) Ralph and Susan listen to Mrs. Brown, and she talks to _____.
- f) The cat plays with Jamie, and he plays with _____.
- g) We see the man, and he sees _____

Thursday:

Feelings

Cut the pics and paste in a colour paper. Label them.

1 happy	2 shy	3 crazy	4 in love
5 hate	6 bored	7 sick	8 angry
9 scared	10 sad	11 tired	12 smart

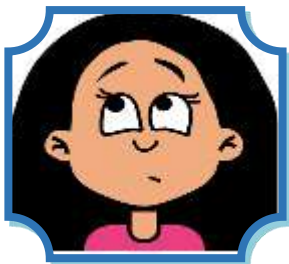
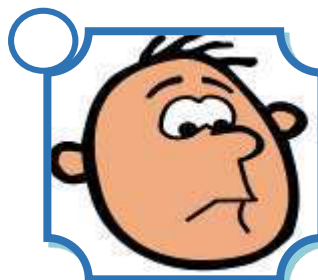
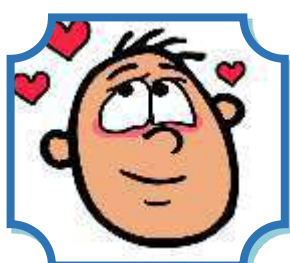

Colour the faces:

HAPPY = **YELLOW**

SAD = **PURPLE**

SICK = **GREEN**

ANGRY = **RED**

CRYING = **BLUE**

SURPRISED = **ORANGE**



Friday. Put a picture of your family and write the correct name according to the numbers.

F
A
M
I
L
Y

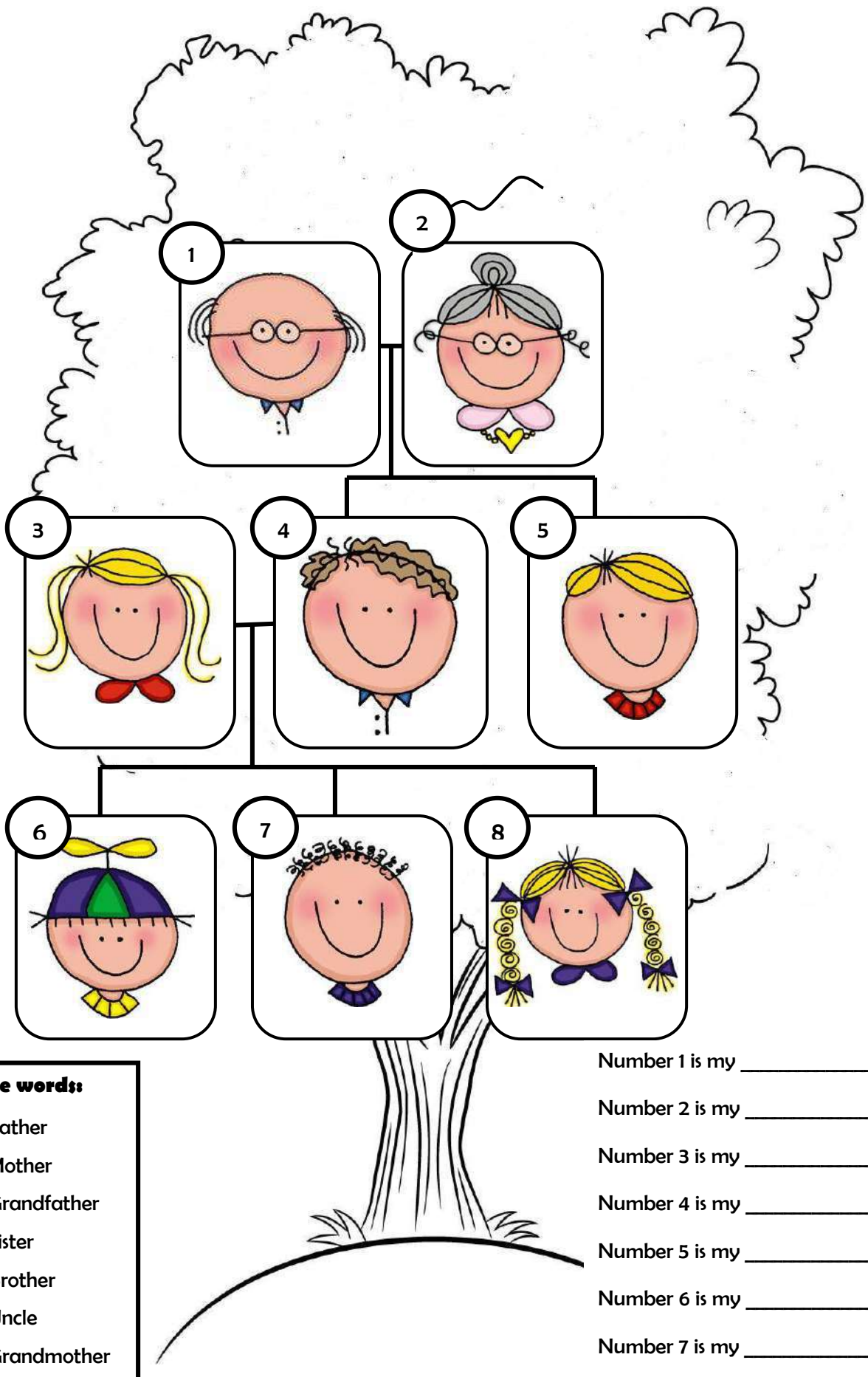

- Use these words:**
- Father
 - Mother
 - Grandfather
 - Sister
 - Brother
 - Uncle
 - Grandmother

Number 1 is my _____.

Number 2 is my _____.

Number 3 is my _____.

Number 4 is my _____.

Number 5 is my _____.

Number 6 is my _____.

Number 7 is my _____.

Number 8 is my _____.

Monday

Cut the pictures and play the Domino. Then paste them on a piece of color paper.



He goes to bed at ten thirty.



Marcos has lunch at twelve.



They start classes in the morning.



He does his homework.



I brush my teeth in the morning.



You go to school in the afternoon.



They take a bath at five



He studies in the morning.



She goes home at three o'clock.



You have dinner in the evening.



I have
breakfast
at seven
thirty.



You take the
bus at
eight
o'clock.



They visit the
friends in
the
afternoon.



She buys
food in the
morning.



Clara listens
to music in
the
evening.



I comb my
hair in the
morning.



They get
dressed at
nine
o'clock.



She watches
TV in the
morning.



My father
cooks at
one
o'clock.



I drink milk in
the
morning.



George
sleeps at
ten
o'clock.



They finish
classes at
one
o'clock.

Tuesday

PRESENT SIMPLE TENSE

I. Write the correct 3rd singular person form. Remember the spelling rules!

Example: eat eats do _____
study _____ watch _____
drink _____ read _____
make _____ learn _____
tidy _____ play _____



Spelling
rules

II. Complete the sentences. Use Present Simple affirmative.

0. My brother plays (play) football.
1. We _____ (eat) hamburgers.
2. I _____ (study) French.
3. My friends _____ (listen) to jazz music.
4. My mum _____ (like) classical music.

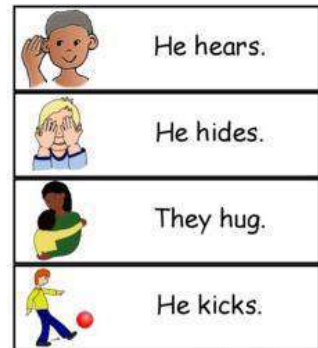

III. Make the sentences negative.

0. I eat pizza.
I don't eat pizza.
1. My brother studies German.

2. We play computer games.

3. Harry likes sport.

4. They drink water.



She doesn't love him.

WEDNESDAY

I. Choose the correct verb form. Circle it.

1. We go/goes to school by bus.
2. My teacher **speak/speaks** Italian and Japanese.
3. We **don't/doesn't** do PE in the classroom.
4. My friends don't **like/likes** art.
5. My mother **teach/teaches** in a primary school.
6. I don't **copy/copies** their homework.
7. They **finish/finishes** work at 8.30 in the evening.
8. We **don't/doesn't** think that English is easy.

II. Write the questions in simple present in the correct order.

0. a book / she / read / Does / ?

Does she read a book?

1. your teacher/Does/English/speak?

2. Does/use/a computer/your mother?

3. ask/your teacher/a lot of questions/Does?

4. CDs and DVDs/copy/Do/you?

5. on Saturday/ to school/go/you/Do?

6. Do/you/French/understand?

7. Does/your school/at half past three/ finish?

THURSDAY

I. Create a small graphic about the activities you do. Write 15 sentences in Present simple using adverbs of frequency in a colour paper. Then paste a picture. Example.

I **sometimes** get up at 6 o'clock.



My routine

I **always** take a shower at 8 o'clock.



II. Write the words for gadgets. Then put a picture.

1. Blteat _____
2. megas loscone _____
3. P3M replay _____
4. Marsthopen _____
5. Ahehndspoe _____
6. SGP _____
7. Plapto _____
8. ard-eere _____

Friday

- I. Create a small graphic about the activities Your father does. Write 15 sentences in Present simple using adverbs of frequency in a colour paper. Then paste a picture. Example.

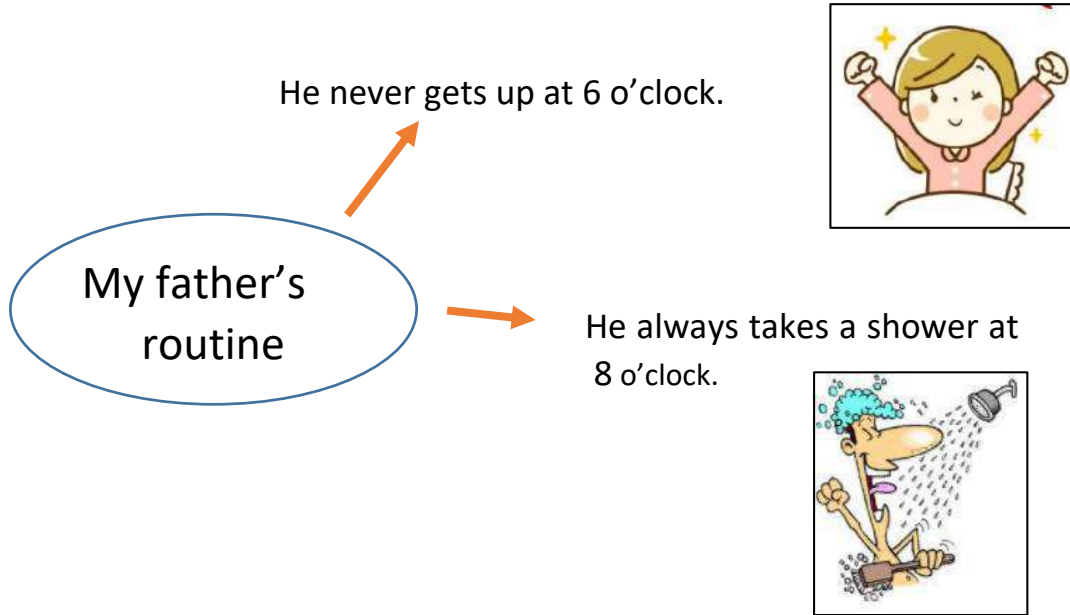

Week 3

Bimestre 3 - Unit 8

Vocabulary: clothes.

Grammar: Present continuous: affirmative, negative and interrogative forms; like / don't like + -ING.

MONDAY

COLOR THE PICTURES.

CUT THEM OUT AND MATCH THEM.

PASTE THEM IN A COLOR PAPER.

FILE IT IN A FOLDER.

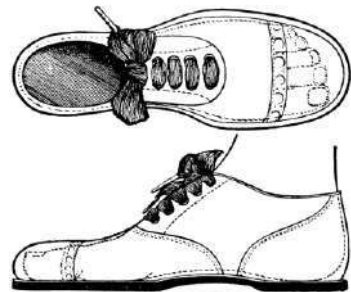
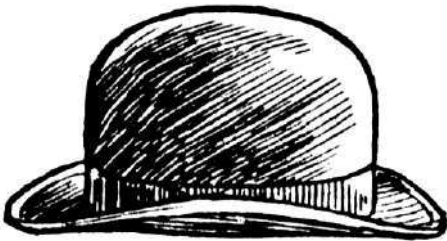

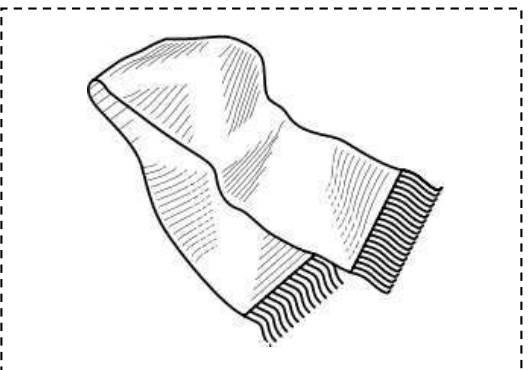
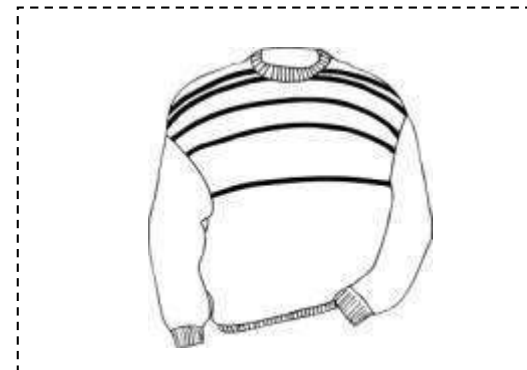

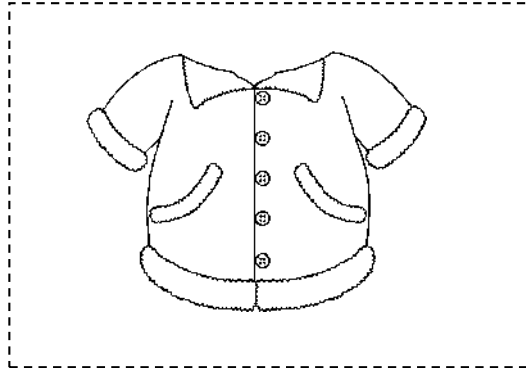
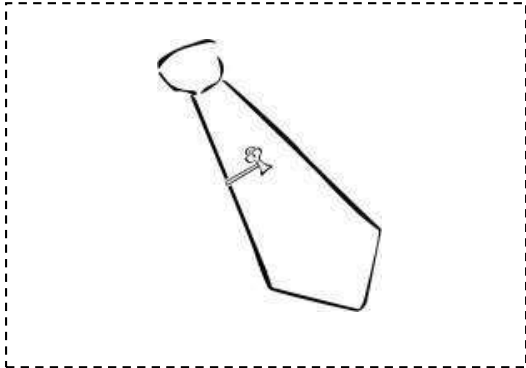
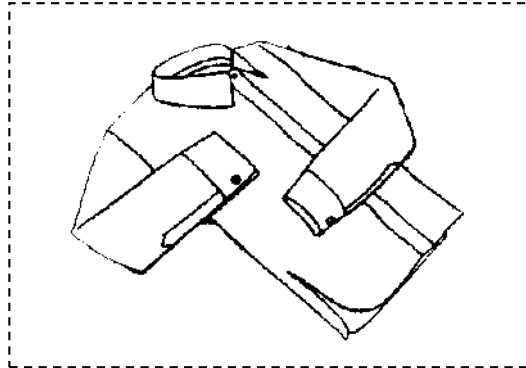
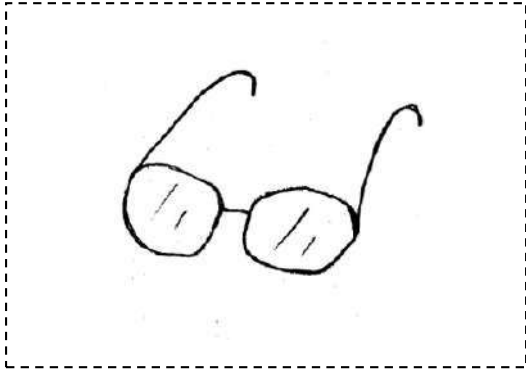

hat

shoes

socks

trainers

dress

skirt

t-shirt

jacket

shorts

gloves

jumper

scarf

glasses

sunglasses

trousers

shirt

tie

coat

TUESDAY

1 Complete the puzzle with names of clothes.



2 Look at the pictures and complete the sentences.



Anna is wearing a green ⁰d_ress and a black ¹c_____.

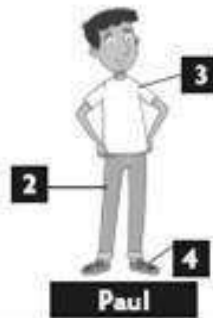

Paul is wearing blue ²t_____, a white ³T-_____ and ⁴t_____.

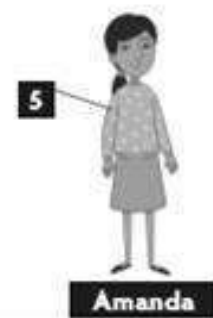

Amanda is wearing a pink ⁵j_____.

3 Complete the sentences so that they are true for you.

- I love wearing _____.
- I hate wearing _____.
- In the winter, I usually wear _____.
- In the summer, I usually wear _____.
- At the moment, I'm wearing _____.

4 Write sentences using the present continuous.

- | | |
|--------------|----------------------|
| 0 she / work | <u>She's working</u> |
| 1 I / dance | _____ |
| 2 you / talk | _____ |
| 3 he / read | _____ |
| 4 we / study | _____ |
| 5 they / run | _____ |

5 Write sentences with like, don't like, love or hate.

- | | |
|---------------------------------|------------------------|
| 0 I / dance ☹️☹️ | <u>I hate dancing.</u> |
| 1 We / shop 😊😊 | _____ |
| 2 Simon / watch TV 😊 | _____ |
| 3 My dog / run 😊😊 | _____ |
| 4 I / study / at the weekend ☹️ | _____ |
| 5 Gina / wear / skirts ☹️☹️ | _____ |

WEDNESDAY

1 Write the -ing form of these verbs.

- 0 swim swimming 2 sit _____ 4 smile _____
1 listen _____ 3 dance _____ 5 fly _____

2 Complete the sentences. Use the present continuous of the verbs.

- 0 I'm not wearing (not / wear) jeans today. 3 Jon _____ (bake) a cake.
1 My dog _____ (sit) on the chair! 4 We _____ (leave) now. Bye!
2 Bill _____ (not / talk) to Suzy. 5 My parents _____ (not / watch) TV at the moment.

3 Write the questions. Use the present continuous.

- 0 you / wear / coat today?
1 you / study / at the moment?
2 Paul / chat / online?
3 your computer / work?
4 those people / play / volleyball?
5 Michelle / run / in the park?

Are you wearing a coat today?

4 Write short answers for the questions in Exercise 3. Use contractions where possible.

- 0 No, I'm not . 3 Yes, _____ .
1 Yes, _____ . 4 No, _____ .
2 No, _____ . 5 Yes, _____ .

5 Circle the correct answers.

- 0 I hate / love swimming. I do it every morning. 4 I like / don't like talking to Mary. She's so interesting.
1 I love dance / dancing. It's my favourite hobby. 5 A Do you like run / running?
2 I don't like go / going to parties. B Yes, but I'm not good at it.
3 I hate / like wearing skirts. I never wear them.

6 Correct the sentences. Use the words in the list.

umbrella | one person | T-shirts | football | park | next to

- 0 The woman is holding a bag.
The woman is holding an umbrella.
1 The boys are playing volleyball.

2 They are playing on a beach.

3 The women are standing behind the men.

4 The boys are wearing coats.

5 Two people are taking photos.



THURSDAY

Write down- What are they doing? Use Present Continuous tense.

It is very nice weather today. The  _____ (shine),

and the birds  _____ (sing).

My family is in the garden. My mother  _____

_____ (sleep) under the tree. My father  _____

(make) some grill chicken for dinner. My brother  _____

(play badminton) with his friend. I  _____ (wash) the car.

It is dinner time. We  _____ (sit) around the table.

FRIDAY

Clothing line

Follow the instructions below.

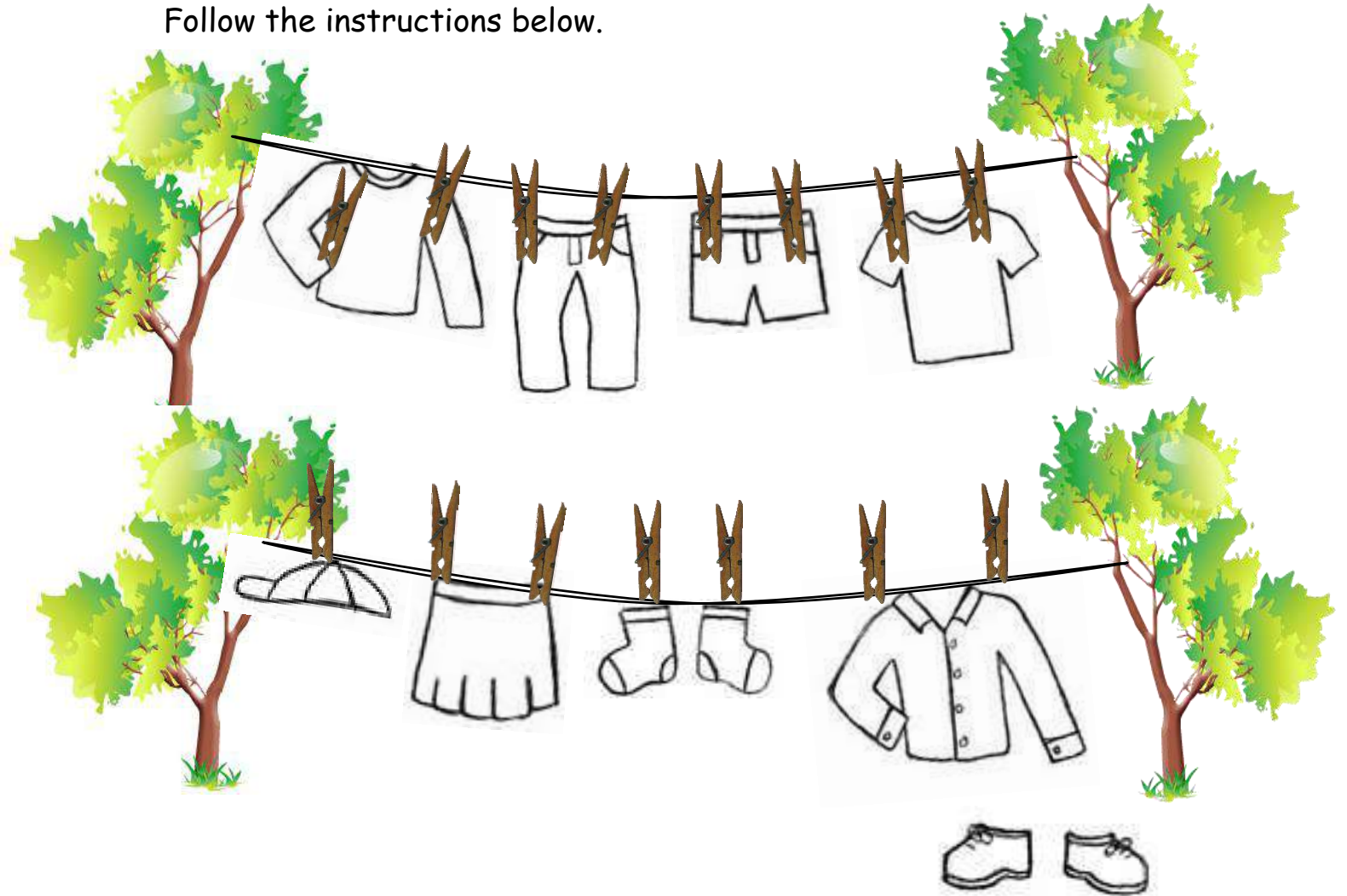

Colour the t-shirt blue.	Colour the socks green.
Colour the skirt pink.	Colour the trousers yellow.
Colour the jumper red.	Colour the shirt purple.
Colour the shoes orange.	Colour the hat black.
Colour the shorts white.	

Week 4

Bimestre 4 - Unit 10

Grammar: Past simple: BE (was / wasn't, were/ weren't; Was he? / Were you ...?)

Past simple: Regular and irregular verbs: affirmative and negative forms.







Vocabulary: time expressions: past; the weather.

MONDAY

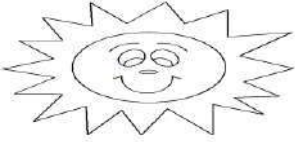
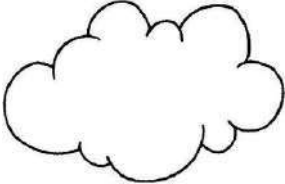
WEATHER

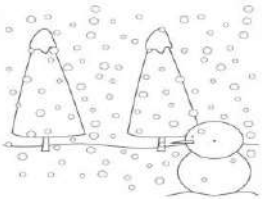
1. **Solve** the word search. **Color** the pictures and **label** them. Then **cut** them to paste them in a color paper. **File** it in a folder.

S	U	N	N	Y	A	V	Y	F
G	C	R	S	T	O	R	M	Y
T	R	S	I	M	C	O	L	D
Z	A	R	S	N	W	K	L	E
W	I	S	N	D	I	G	H	T
R	N	A	O	C	N	L	U	W
A	Y	Q	W	C	D	M	K	L
T	Z	X	Y	V	Y	S	U	W
C	L	O	U	D	Y	H	O	T

S _____	C _____	R _____	S _____
			
W _____	ST _____	H _____	C _____
			

2 Write the weather words.



0 It's sunny.

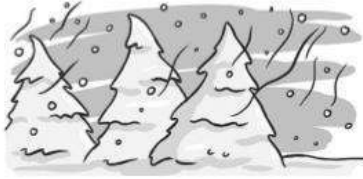

1 It's _____.



2 It's _____.



3 It's _____.



4 It's _____.

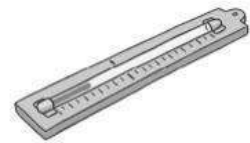

5 It's not warm, it's _____.

PAST TIME EXPRESSIONS

3 Complete the sentences with *in, at, last, or yesterday*.

0 Yesterday afternoon, I was with Jenny in the café.

1 I finished my homework _____ midnight.

2 I was at the party _____ weekend.



3 My grandmother was born _____ 1946.



4 I arrived in London _____ morning.

5 It snowed a lot _____ month.



TUESDAY (revise the last page of your workbook - irregular verbs)



LOOK AT THE PICTURES AND FILL IN THE CROSSWORD PUZZLE.

13  **14** 



1  **2** 



build **3**  **bite** **ride**





12  **4**  **3** **burn**

11  **5**  **4**

eat **10.** **11.** **6**  **learn**

10  **12.** **7**  **5**

forgive **13.** **14.**  **6** 

9  **8**  **7**  **6**  **give**

write **come** **leave** **cut**

THE HIDDEN WORDS ARE _____.

WEDNESDAY

1 Circle the correct words.

- 0 It was / were sunny yesterday.
- 1 I was / were born in 1997.
- 2 I'm sorry we was / were late today.
- 3 My grandfather was / were a police officer.
- 4 You was / were a very beautiful baby.
- 5 John and Kinga was / were very happy when they lived in Madrid.

2 Complete the sentences with *was*, *wasn't*, *were*, or *weren't*.

- 0 It wasn't very warm yesterday. It was cold.
- 1 You _____ so sad yesterday. What was the problem?
- 2 I arrived home late last night, but my parents _____ angry.
- 3 Michael _____ very worried before his exam, but he did OK in the end.
- 4 My mother _____ born in July, her birthday is in June.
- 5 We _____ late because we missed our train.

3 Put the words in order to make questions.

- 0 at / were / park / yesterday / you / the
- 1 morning / I / was / this / late
- 2 keys / were / in / your coat / the
- 3 Anna / party / last / at / was / the / night
- 4 interesting / were / books / those
- 5 the / busy / was / restaurant

Were you at the park yesterday? _____

4 Write short answers for the questions in Exercise 6.

- 0 No, I wasn't.
- 1 Yes, _____.
- 2 No, _____.
- 3 Yes, _____.
- 4 Yes, _____.
- 5 No, _____.

5 Complete the sentences with the past simple form of the verbs in brackets.

- 0 I helped (help) Matteo a lot when he was ill.
- 1 I _____ (hate) vegetables when I was a child.
- 2 We _____ (move) to Paris in 2014.
- 3 I _____ (start) a new book last night.
- 4 Liam _____ (try) to call George, but he was busy.
- 5 Nora and Rob _____ (work) a lot last week.



JUSTIN BIEBER

I.- Complete the story with verbs in the past.

Justin Bieber _____(be) born in 1994, in Stratford, Ontario, Canada. As a child, He _____(have) a lot of interest on music. He _____(begin) to perform when he _____(be) 12. He _____(enter) to a local talent competition, and he _____(be) placed second. He _____(get) the opportunity of posting his performances in YouTube.

The videos soon _____(build) up a fan following, and _____(catch) the attention of talent agent Scooter Braun. Braun _____(be) able to secure an audition with Usher Raymond, who _____(be) impressed and _____(help) Bieber to sign a record deal. His first single "One Time", _____(be) a worldwide hit. This was _____(follow) by Bieber's debut album, "My World", which _____(be) an international smash. He also _____(release) a successful concert film Justin Bieber: Never Say Never in 2011.

Bieber _____(try) his hand at acting. He _____(play) a young killer in an episode of "C.S.I." in 2000. He has a large and loyal fanbase, who are said to have 'Bieber Fever' and are nicknamed 'Bielbers'. Bieber continues with a hugely successful music career.

II. Answer the questions about Justin Bieber

1. Who is Justin Bieber? _____
2. Where was he born? _____
3. When was he born? _____
4. Where did he post his performances? _____
5. Who is his agent? _____
6. What was his first single? _____
7. When did he release his concert film "Never Say Never"? _____
8. When did he play a young killer in an episode of "C.S. I."? _____

FRIDAY: Flashcards (color, cut and paste them on cardboard. Then study).

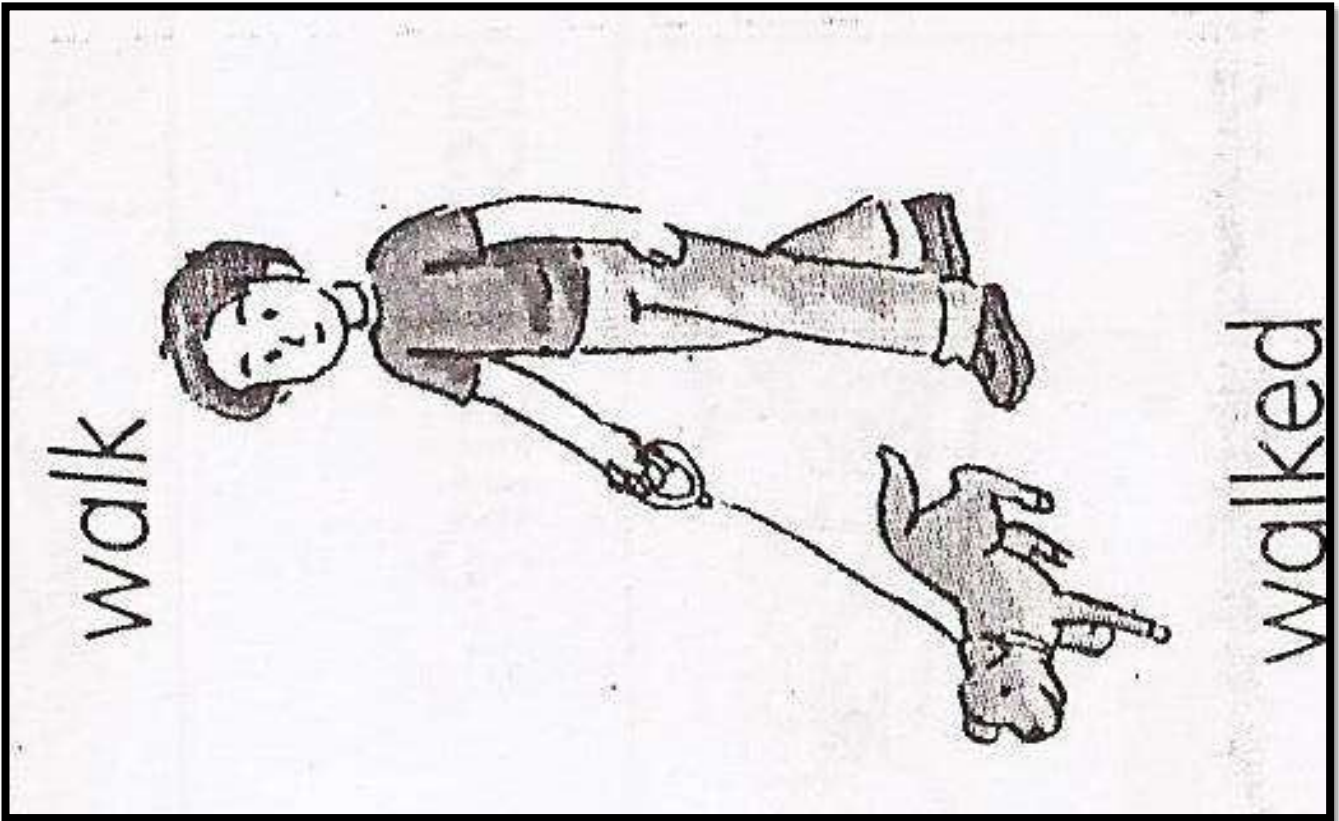
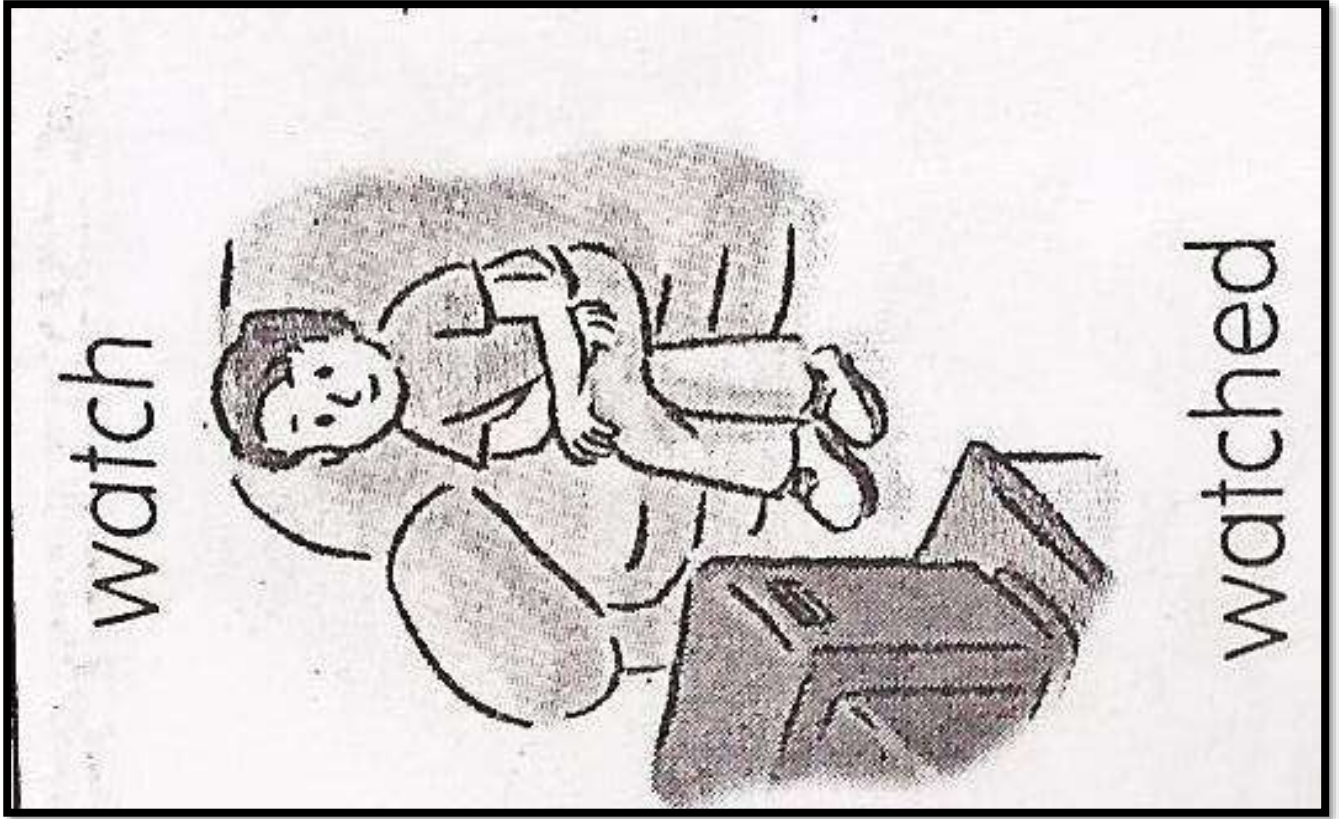

talk

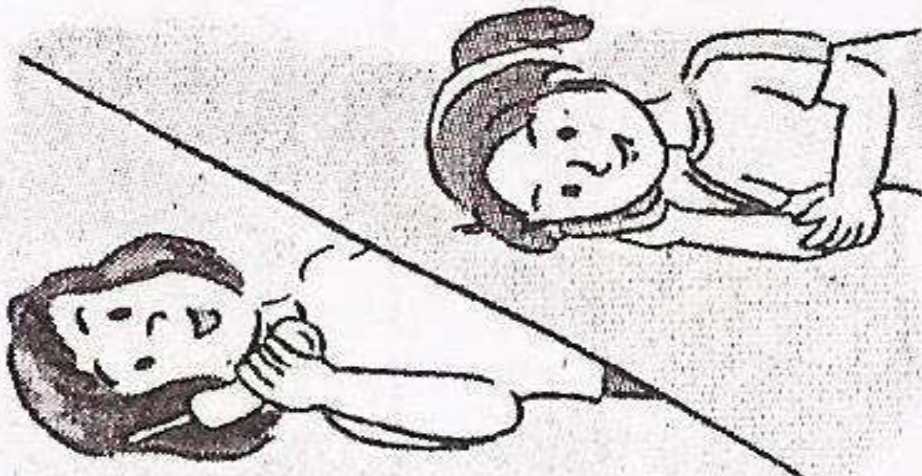

talked

visit



visited

study

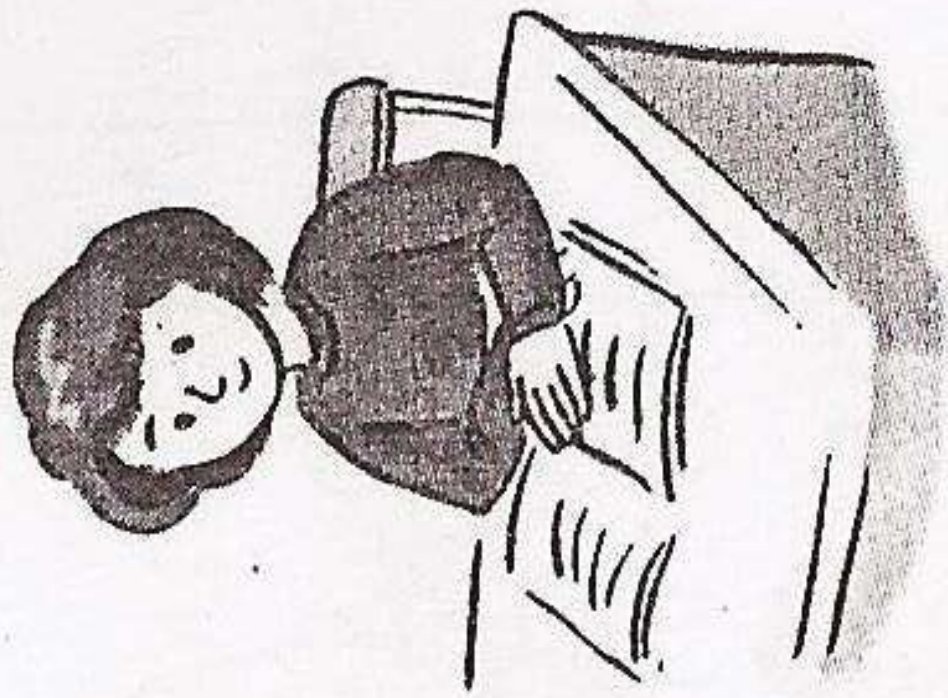

studied

play

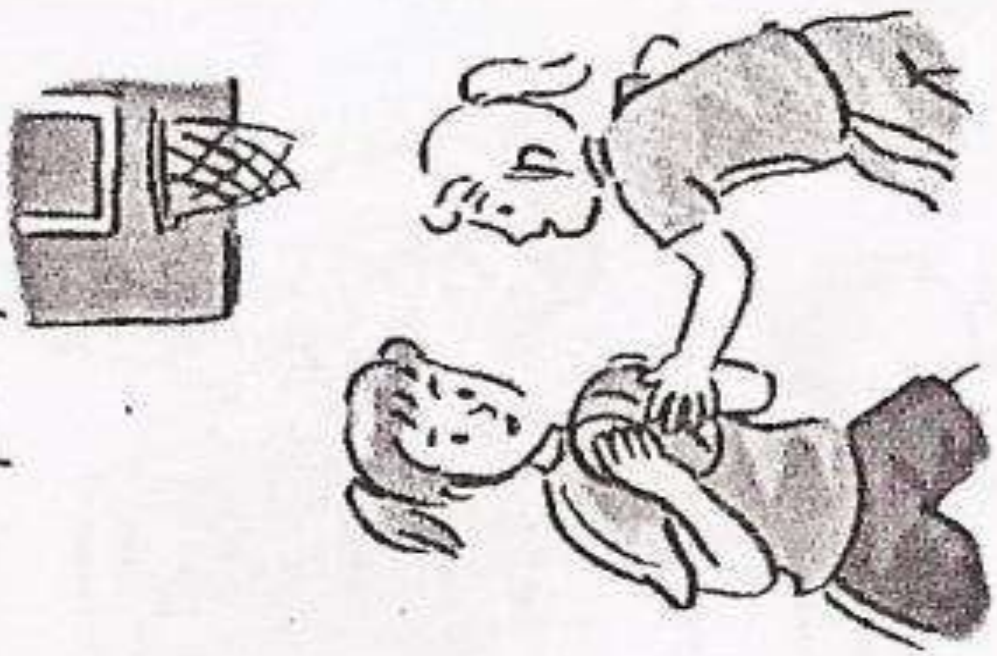

played

plant



planted

cleaned



clean

practice

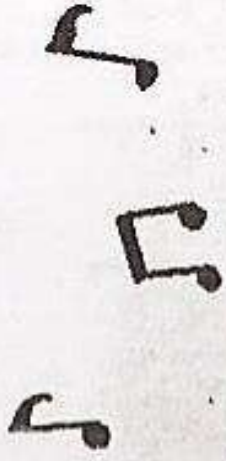

practiced

bake



baked



Inventario de actividades de Inglés (nivel: BASIC) (Apoyo a la recuperación académica 2017)

Estimado estudiante:

Te proponemos el presente inventario de actividades como un recurso de apoyo para el proceso de recuperación académica que debes seguir durante el mes de enero de 2018. Te pedimos tener presente, respecto al inventario, lo siguiente:

- Ha sido elaborado de acuerdo con un temario anual, el cual considera los cuatro bimestres (25 % c/u).
- Las actividades que se presenta en él han sido tomadas de documentos de trabajo, libros del año escolar 2017 y de otras fuentes, pero que se ajustan a los contenidos del temario anual.
- Ha sido dosificado para ser desarrollado en cuatro semanas, de lunes a viernes, destinando para ello una hora diaria aproximadamente.
- El estudiante debe imprimir los documentos que serán desarrollados, archivados y presentados en un fólder manila tamaño oficio (incluir carátula), el mismo que será revisado y evaluado por los docentes responsables de la evaluación de recuperación, asignándole un peso de 25 % en el resultado final de la recuperación como "evaluación de portafolio". De hecho, si no lo presentases desarrollado, se te asignará la nota mínima en evaluación de portafolio.
- Si los estudiantes requiriesen presentarse a la segunda oportunidad, podrán mejorar y volver a presentarlo desarrollado, prevaleciendo, en este caso, la segunda calificación. Si no lo hiciesen, mantendrán la calificación obtenida en la primera ocasión.
- En la tabla de control diario, el padre de familia debe firmar para apoyar y controlar el avance diario del estudiante en su desarrollo.
- No hemos incluido una calendarización específica para su desarrollo (fechas de inicio y fin), asumiendo que cada estudiante lo hará en coordinación con sus padres, considerando la realidad particular y los planes de la familia. En todo caso, el trabajo ha sido previsto para cuatro semanas.
- La primera oportunidad de evaluación será a fines de enero. La presentación del portafolio (inventario desarrollado) es obligatoria desde la primera oportunidad de evaluación.

SEMANA 1	BIMESTRE 1	TEMA 1	CLOTHING	Worksheet 1
		TEMA 2	SIMPLE PRESENT TENSE	Worksheet 2
SEMANA 2	BIMESTRE 2	TEMA 3	FAMILY MEMBERS	Worksheet 3
		TEMA 4	SIMPLE PAST : WAS WERE	Worksheet 4
SEMANA 3	BIMESTRE 3	TEMA 5	SPORTS	Worksheet 5
		TEMA 6	SIMPE PAST VS. PAST CONTINUOUS	Worksheet 6
SEMANA 4	BIMESTRE 4	TEMA 7	GEOGRAPHICAL FEATURES	Worksheet 7
		TEMA 8	SUPERLATIVES	Worksheet 8

Tabla de firmas del padre de familia de control diario					
	Lunes 1 de enero	Martes 2 de enero	Miércoles 3 de enero	Jueves 4 de enero	Viernes 5 de enero
Semana 1					
	Lunes 8 de enero	Martes 9 de enero	Miércoles 10 de enero	Jueves 11 de enero	Viernes 12 de enero
Semana 2					
	Lunes 15 de enero	Martes 16 de enero	Miércoles 17 de enero	Jueves 18 de enero	Viernes 19 de enero
Semana 3					
	Lunes 22 de enero	Martes 23 de enero	Miércoles 24 de enero	Jueves 25 de enero	Viernes 26 de enero
Semana 4					

WEEK 1

WORKSHEET 1

I. Match the things with the shops.

0. shoes shoe shop
1. packet of cereal _____
2. medicine _____
3. trainers _____
4. newspaper _____
5. jeans _____

newsagent's
sports shop
clothes shop
chemist's
~~shoe shop~~
supermarket

II. Complete the name of the clothes.

Example:



0. s a n d a l s



1. _ r _ s _

2. B _ _ _

3. S _ _ r _

4. _ a c _ _ _

5. B _ _ _ s

III. Write the name of the different clothes items.

0



shoes

1



2



3



4



5



WORKSHEET 2

IV. Underline the correct verb form.

0. My friend *love* / loves ice cream.
1. Mario wash / washes his car every week.
2. We eat / eats an apple every day.
3. Max always watch / watches TV after school.
4. They do / does their homework in the evening.
5. I start / starts school at eight o'clock.
6. Nadia usually have / has lunch at school.

V. Match the questions and answers.

- 1 Does he walk to school every day?
- 2 Do you go to school by car?
- 3 Do you always watch TV on Sundays?
- 4 Do they play football on Saturdays?
- 5 Does she usually play computer games?

- a No, I don't. I walk to school.
- b Yes, they do. They're in the school team.
- c No, she doesn't. She likes reading books.
- d No, he doesn't. He goes by car.
- e Yes, I do. I like watching basketball.

VI. Complete the text with the PRESENT SIMPLE of the verbs in brackets.

David ¹..... (like) yoghurt and he ²..... (eat) an apple every day.

He is healthy! He usually ³..... (have) lunch in the school canteen and in the evenings, he ⁴..... (go) running.



VII. Underline the correct form of the verb.

0. You don't / doesn't understand!
1. Sally don't / doesn't like oranges.
2. The children don't / doesn't watch TV in the morning.
3. I don't / doesn't take the dog for a walk every day.
4. Tom don't / doesn't read magazines.
5. We don't / doesn't eat hamburgers.

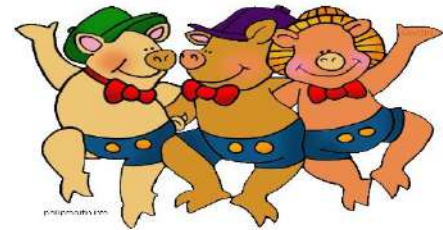

They don't sing.

VIII. Rewrite the sentences in the NEGATIVE FORM.

0. I get up at seven o'clock.
I don't get up at seven o'clock
1. They listen to music every day.
.....
2. Sarah goes shopping.
.....
3. Mark plays computer game
.....
4. You go roller skating.
.....
5. We have breakfast at 8 o'clock.
.....



She doesn't love him.

IX. Write questions and short answers. (X = negative).

0. Sarah / catch the bus every morning (✓)
Does Sarah catch the bus every morning?
Yes, she does.

1. Fred / play football in a team (X)
?

2. Mike and Sally / go shopping on Fridays (X)
?

3. Sarah / play the piano (✓)
?

4. you / do your homework in the afternoon (✓)
?



X. Answer the questions, in a complete form, about yourself.

1. What time do you usually get up in the morning?

2. And what time do you usually go to bed?

3. Do you sometimes play computer games?

WEEK 2

WORKSHEET 3

I. Write the name of your relatives and extended family.

0. The parents of your parents are your GRANDPARENTS

1. The father of your father/mother. _____
2. The mother of your father/mother. _____
3. The children of your children. _____
4. The son of one of your children. _____
5. The daughter of one of your children. _____
6. The father of your grandfather/grandmother. _____
7. The mother of your grandfather/grandmother. _____



8. The brother (or brother-in-law) of your mother/father. _____
9. The sister (or sister-in-law) of your mother/father. _____
10. The child of your aunt/uncle. _____
11. The male child of your brother/sister. _____
12. The female child of your brother/sister. _____

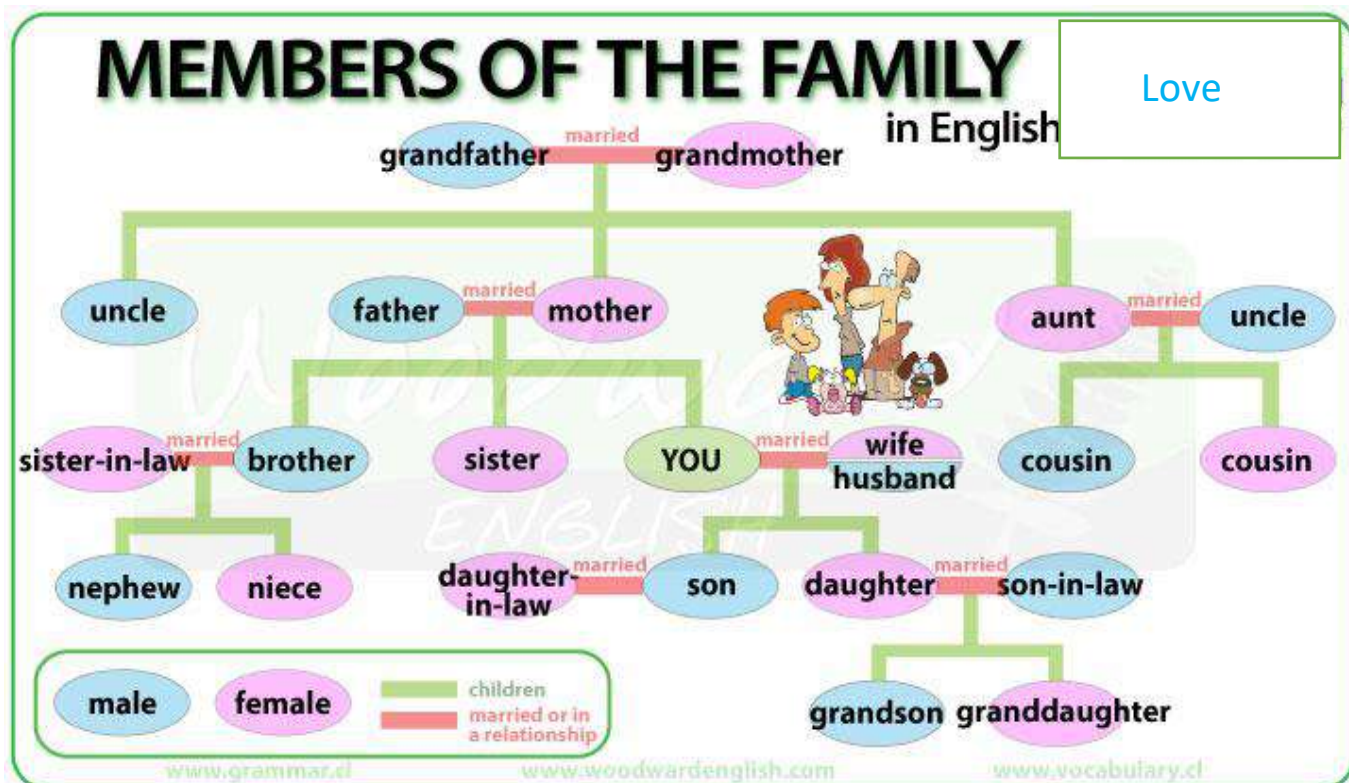

II. Complete this family tree.

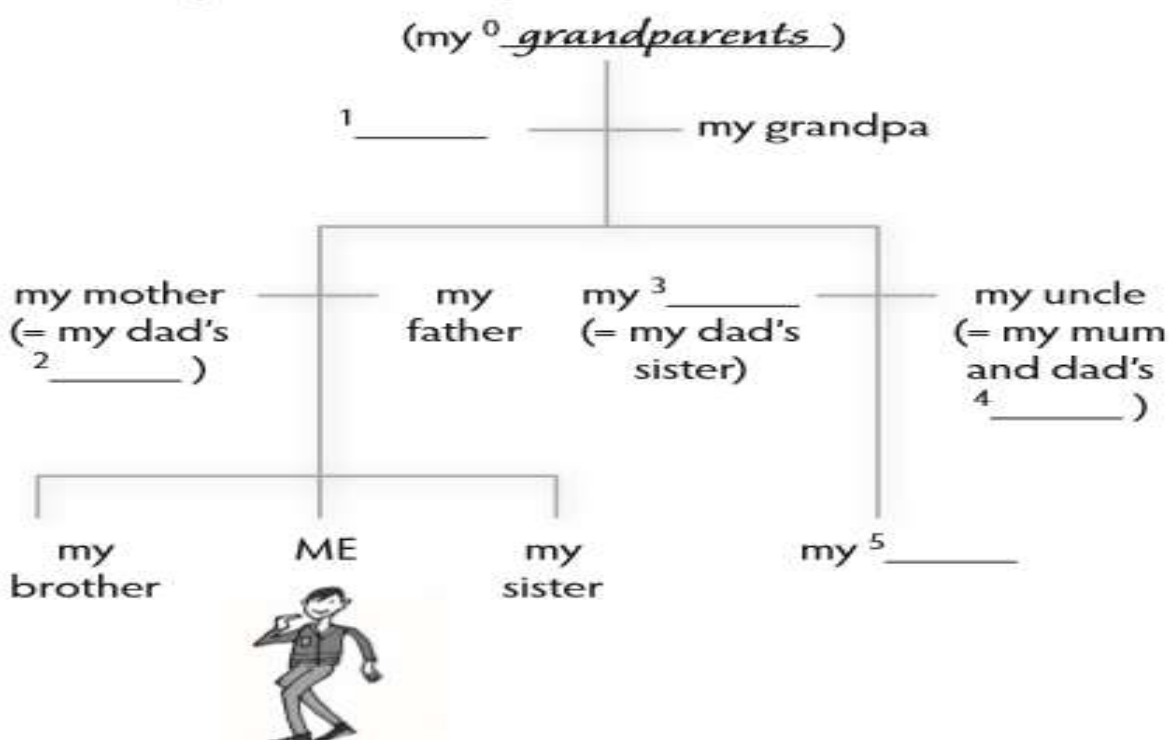

WORKSHEET 4

III. Complete the conversations. Use the PAST SIMPLE form of TO BE.

0. A Were you at school yesterday?
B No, I wasn't.
1. A. _____ John upset about Mary?
B. No, he _____ .
2. A. _____ the film good?
B. No, it _____ very boring.
3. A. _____ there many people at the museums?
B. Yes, there _____ a lot of tourists.
4. A. Where _____ you and your brother at the weekend?
B. We _____ at home.
5. A. _____ Pat and Sarah at Jane's party?
B. No, they _____ .

WAS and WERE

AFFIRMATIVE	
I	WAS
YOU	WERE
HE	} WAS
SHE	
IT	} WERE
WE	
YOU	
THEY	

NEGATIVE	
I	WASN'T
YOU	WEREN'T
HE	} WASN'T
SHE	
IT	} WEREN'T
WE	
YOU	
THEY	

INTERROGATIVE	
WAS	I ... ?
WERE	YOU ... ?
WAS	HE ... ?
	SHE ... ?
WERE	IT ... ?
	WE ... ?
	YOU ... ?
	THEY ... ?

It **was** rainy yesterday.



It **wasn't** sunny yesterday.

Was it rainy yesterday?

1) Underline the correct verb.

Example: We was / were at the zoo last Sunday.

- Tom **wasn't** / **weren't** at school last week.
- It **was** / **were** cold yesterday.
- My parents **wasn't** / **weren't** in Italy last year.
- Sally **was** / **were** in the country at the weekend.

- Sarah **wasn't** / **weren't** happy yesterday.
- They **was** / **were** late for school last Tuesday.
- Dave **wasn't** / **weren't** tired yesterday.
- Ted and Jill **was** / **were** at the theatre last night.

2) Rewrite the sentences in the past simple.

Example: I'm not at school. I **wasn't** at school.

- Mark isn't here. _____
- This dog is funny. _____
- I am not busy. _____
- You are very lucky. _____
- The winter is cold. _____
- They aren't tired. _____
- We are hungry. _____
- This book isn't boring. _____

**3) Make questions with the following words.
Write the answers to the questions.**

Example: you / at the zoo / yesterday / were
Were you at the zoo yesterday? Yes, I was.

1. you / at the party / two days ago / were

No, I _____

2. the shops / open / were / last Sunday

Yes, they _____

3. Sam / last week / was / at the museum

Yes, he _____

4. at the sports centre / they / last Monday / were

No, they _____

5. sick / yesterday / were / Sally and her sister

Yes, they _____

6. the weather / cold and wet / was / last Tuesday

No, it _____

7. in London / Jane / last year / was

Yes, she _____

4) Complete the questions with was and were

Example:

Was it cold yesterday?

Yes, it was.

1.

_____ at the cinema last night?

2.

_____ at home
yesterday?

No, they weren't.
Adam and Ann
weren't at the
cinema last night.

3.

_____ at Paul's
birthday party last
Saturday?

Yes, I was.

4.

_____ your
birthday last
Monday?

Yes, she was.
Mary was there.

No, it wasn't. It
was my brother's
birthday last
Monday.



WEEK 3

Worksheet 6

I. Complete the following text using the PAST TENSE of the verbs in brackets.

Anna's holiday _____ (be) great last summer. She _____ (stay) in a college in England for two weeks. She _____ (have) classes in the mornings and in the afternoons she _____ (do) some sports like swimming or tennis. In the evenings she often _____ (go) dancing or _____ (watch) films with her new friends.

At weekends they _____ (drive) to some interesting places. Once they _____ (visit) Marwell Zoo where they _____ (see) some beautiful animals. Anna _____ (not like) the food at the college but that _____ (not be) a problem. She _____ (meet) a lot of people and _____ (learn) some English. All the students in her class _____ (be) sorry to go home. They all _____ (promise) to come back next summer.

II. Here are the things Anna wanted to do last weekend. She didn't do all of them. Write what she did or didn't do.

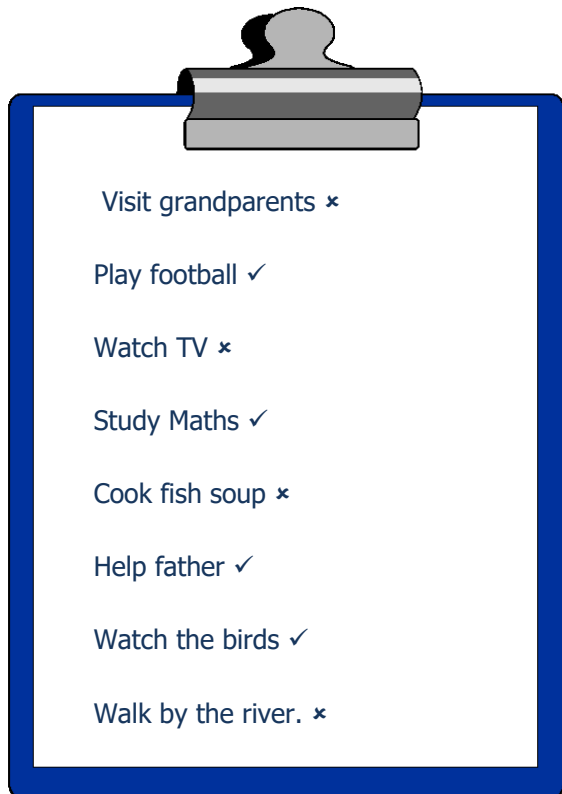

1. She didn't visit her grandparents.
2. _____
3. _____
4. _____
5. _____
6. _____
7. _____
8. _____

III. Put the verbs into the correct form. Use PAST CONTINUOUS structures.

1. When I phoned my friends, they (play) **were playing** monopoly.
2. Yesterday at six I (prepare) _____ dinner.
3. The kids (play) _____ in the garden when it suddenly began to rain.
4. I (practice) _____ the guitar when he came home.
5. We (not / cycle) _____ all day.
6. While Alan (work) _____ in his room, his friends (swim) in the pool.
7. I tried to tell them the truth but they (not / listen) _____
8. What (you / do) _____ yesterday?
9. Most of the time we (sit) _____ in the park.
10. I (listen) _____ to the radio while my sister (watch) TV.
11. When I arrived, They (play) _____ cards.
12. We (study) _____ English yesterday at 4:00 pm.

IV. Fill in the blanks with a correct form. Use PAST SIMPLE or PAST CONTINUOUS structures.

1. We **were playing** (play) volleyball with Mary, when you **called** (call) me.
2. When the teacher _____ (come) in, they _____ (study) English.
3. The baby _____ (sleep) when the telephone _____ (ring).
4. As I _____ (walk) in the streets of Holland, I _____ (meet) an old friend of mine.
5. My neighbor (meet) _____ her husband while she (travel) _____ around Catalonia.
6. I _____ (look) for my purse when I _____ (drop) my credit card.
7. Shakira (sing) _____ in a concert when she (lose) _____ her voice.
8. While I (have) _____ a shower, the lights (go out) _____.
9. We (drive) _____ to the hospital when the baby (be born) _____.
10. My mother (lose) _____ her purse when she (walk) _____ home.



WEEK 4

Worksheet 7

Worksheet 8

I. Complete with a superlative adjective and all the necessary words.

1. London is (large) city in England.
2. Cheetahs are (fast) animals in the world.
3. Whales are (big) animals.
4. San Francisco is (beautiful) city in the United States.
5. Summer is(good) season of the year.

II. Write the superlative form.

- | | |
|--------------------|---------------------|
| 1. good | 6. pretty |
| 2. far | 7. small |
| 3. expensive | 8. nice |
| 4. old | 9. comfortable..... |
| 5. young | 10. bad |

III. Look at the information in the picture. Write 10 sentences using SUPERLATIVE adjectives.



Example:

Tom is the oldest in the group.

1. _____.
2. _____.
3. _____.
4. _____.
5. _____.
6. _____.
7. _____.
8. _____.
9. _____.
10. _____.



Inventario de actividades de Inglés (nivel: INTERMEDIATE) (Apoyo a la recuperación académica 2017)

Estimado estudiante:

Te proponemos el presente inventario de actividades como un recurso de apoyo para el proceso de recuperación académica que debes seguir durante el mes de enero de 2018. Te pedimos tener presente, respecto al inventario, lo siguiente:

- Ha sido elaborado de acuerdo con un temario anual, el cual considera los cuatro bimestres (25 % c/u).
- Las actividades que se presenta en él han sido tomadas de documentos de trabajo, libros del año escolar 2017 y de otras fuentes, pero que se ajustan a los contenidos del temario anual.
- Ha sido dosificado para ser desarrollado en cuatro semanas, de lunes a viernes, destinando para ello una hora diaria aproximadamente.
- El estudiante debe imprimir los documentos que serán desarrollados, archivados y presentados en un fólter manila tamaño oficio (incluir carátula), el mismo que será revisado y evaluado por los docentes responsables de la evaluación de recuperación, asignándole un peso de 25 % en el resultado final de la recuperación como "evaluación de portafolio". De hecho, si no lo presentases desarrollado, se te asignará la nota mínima en evaluación de portafolio.
- Si los estudiantes requiriesen presentarse a la segunda oportunidad, podrán mejorar y volver a presentarlo desarrollado, prevaleciendo, en este caso, la segunda calificación. Si no lo hiciesen, mantendrán la calificación obtenida en la primera ocasión.
- En la tabla de control diario, el padre de familia debe firmar para apoyar y controlar el avance diario del estudiante en su desarrollo.
- No hemos incluido una calendarización específica para su desarrollo (fechas de inicio y fin), asumiendo que cada estudiante lo hará en coordinación con sus padres, considerando la realidad particular y los planes de la familia. En todo caso, el trabajo ha sido previsto para cuatro semanas.
- La primera oportunidad de evaluación será a fines de enero. La presentación del portafolio (inventario desarrollado) es obligatoria desde la primera oportunidad de evaluación.

Semana 1

Bimestre 1

UNIT 3 THAT'S ENTERTAINMENT

GRAMMAR: Comparative and Superlative Adjectives; (not) as ... as; Adverbs; making a comparison stronger or weaker.

VOCABULARY: Types of films, TV programs; expressions with GET

Semana 2

Bimestre 2

UNIT 6 MAKING A DIFFERENCE

GRAMMAR: Will (not) May (not), Might (not), First Conditional

VOCABULARY: The environment; verbs to talk about energy

Semana 3

Bimestre 3

UNIT 8 SCIENCE COUNTS

GRAMMAR: past simple vs past continuous; used to; Second conditional; I wish

VOCABULARY: direction and movement; science

Semana 4**Bimestre 4****UNIT 9 -10 WHAT A JOB! - KEEP HEALTHY**

GRAMMAR: Passive voice (present simple and past simple, present perfect and present continuous); Past Perfect vs Past Perfect Continuous

VOCABULARY: Jobs; work as/ in/ for vs job; time expression with *in*; Time linkers; illness collocations.

	Tabla de firmas del padre de familia de control diario				
	Lunes 1 de enero	Martes 2 de enero	Miércoles 3 de enero	Jueves 4 de enero	Viernes 5 de enero
Semana 1					
	Lunes 8 de enero	Martes 9 de enero	Miércoles 10 de enero	Jueves 11 de enero	Viernes 12 de enero
Semana 2					
	Lunes 15 de enero	Martes 16 de enero	Miércoles 17 de enero	Jueves 18 de enero	Viernes 19 de enero
Semana 3					
	Lunes 22 de enero	Martes 23 de enero	Miércoles 24 de enero	Jueves 25 de enero	Viernes 26 de enero
Semana 4					

ANEXOS



INGLÉS

INTERMEDIO

INVENTARIO DE EJERCICIOS, PROBLEMAS Y ACTIVIDADES – APOYO A LA RECUPERACIÓN ACADÉMICA 2017

Docentes responsables: - JORGE RAFAEL PAREDES SANCHEZ

- REBECA PEREZ ACEVEDO

Anexo 1

BIM I

Monday

Week 1

I. Read the sentences. Write **S** if they have the same meaning and **D** if the meaning is different.

- 0 I'm not as clever as you. / You are more intelligent than me. S
- 1 My son is younger than yours. / My son isn't as old as yours. ____
- 2 Cats are more independent than dogs. / Dogs aren't as independent as cats. ____
- 3 I'm not as clever as you. / You are more intelligent than me. ____
- 4 My son is younger than yours. / My son isn't as old as yours. ____
- 5 Cats are more independent than dogs. / Dogs aren't as independent as cats. ____

II. Match the film descriptions to the films.

- | | |
|--|--------------------|
| 1. _____ A film which tells real life stories,
especially about animals and places. | A. Documentary |
| 2. _____ A film which combines comedy and love stories. | B. Thriller |
| 3. _____ A film where frightening things happen and you feel scared. | C. Horror film |
| 4. _____ A film that it's often about solving a crime. | D. Romantic comedy |

III. Complete the sentences with adjectives.

1. Mum gets up _____ Dad in the morning. She gets up _____ (early)
2. I do my homework _____ my brother. I am more _____ him (careful)
3. Tia studies _____ for her exams than me. (hard)
4. Grandma drives _____ at night. She drives _____ Granddad (slow)

Tuesday

I. Complete the sentences with *as...as/notas... as* so with your ideas. Use the words in the list.

enjoyable | delicious | ~~difficult~~ interesting | relaxing | exciting

0. English is not as difficult as Maths.
1. Horror films are _____ action films.
2. Sports programmes are _____ reality shows.
3. A film is _____ a TV programme.
4. A play is _____ a concert.

II. Write the correct television programmes.

- TOM** I got really excited when my team scored a goal quite at the end of the match. sports programmes
- YAZ** I knew all the answers! g_____ s_____
- ANA** Have you seen the latest episode? It was really funny. s_____
- JOE** Zane was voted off the show yesterday. r_____ s_____
- LUCIA** I think Rebecca Jones sings beautifully; she should be the winner. t_____ s_____
- TOBY** I watched *Tom and Jerry* yesterday and I laughed a lot. c_____

III. Complete the text. Use the correct comparative or superlative form of the adjectives.



www.reviews.uk

MOVIE REVIEWS

Spaceman 2 is the ⁰ best (good) new sci-fi/action film for a long time. The special effects in this film are ¹ _____ (good) *Spaceman 1* and the story is ² _____ (interesting). But, the film was ³ _____ (expensive) *Spaceman 1* to make – it cost \$250 million. Many people thought that *Spaceman 1* was the ⁴ _____ (bad) film ever made but I think this ⁵ _____ (late) film is a bit better.



Wednesday

I. Write adverbs

- | | |
|------------------|---------------|
| 1. Careful _____ | 5. Bad _____ |
| 2. Clever _____ | 6. Easy _____ |
| 3. Clear _____ | 7. Fast _____ |
| 4. Good _____ | 8. Slow _____ |

II. Fill in the blanks with the correct form of the adjectives in brackets

1. The weather this summer is _____ (hot) last summer.
2. Football is _____ (popular) sport in the world.
3. Cheetahs are _____ (fast) lions or tigers. In fact, they are _____ (fast) animals in the world.
4. He is _____ (bad) cook I have ever met.
5. Alan is _____ (tall) Clive and Brett, but Brett is _____ (fat) of the three.

III. Complete the table.

Adjective	Comparative	Superlative
big	bigger	0 <i>the biggest</i>
1 _____	taller	2 _____
3 _____	4 _____	the prettiest
expensive	5 _____	6 _____
7 _____	more interesting	8 _____
9 _____	10 _____	the most difficult
good	11 _____	12 _____
13 _____	worse	14 _____



Thursday

I. Read the entertainment guide. Match.

- | | | |
|-------------------------|-------|---|
| 0 Today | _____ | b |
| 1 Police Detectives | _____ | |
| 2 The \$1,000,000 Quiz | _____ | |
| 3 Star in My Car | _____ | |
| 4 The Sound | _____ | |
| 5 Nutty Antiques | _____ | |
| 6 I Want to Go Home! | _____ | |
| 7 Old Bernard's Balloon | _____ | |

- a talent show
- b news
- c reality show
- d drama series
- e sitcom
- f talk show
- g cartoon
- h game show

II. Read the entertainment guide again. Mark these sentences T (true), F (false), or DS (doesn't say).

- 1 Today is a comedy show about the news. T
- 2 In Police Detectives, two police officers make jokes. _____
- 3 The questions are very difficult on The \$1,000,000 Quiz. _____
- 4 Star in My Car isn't as interesting as other talk shows. _____
- 5 Many singers who are famous now won The Sound. _____
- 6 Nutty Antiques isn't as funny as other sitcoms. _____
- 7 The celebrities on I Want to Go Home! often disagree with each other. _____
- 8 The presenter in Old Bernard's Balloon is not animated. _____

III. Complete the sentences with your own ideas. Use *a lot*, *much*, *far*, *a little*, *a bit*.

0. Action films are much better than thrillers.
1. Game shows _____ reality shows.
2. A concert _____ a play
3. Staying in a hotel _____.
4. History _____ Geography.
5. Classical music _____ rock music.

These days, you can easily watch TV online. Not everything's good, of course, but here are our recommendations.

LIKE • COMMENT • SHARE

Today
A look at what's in the news around the world.

Police Detectives
This exciting new show is about two police officers in Chicago. They investigate crimes and catch criminals.

The \$1,000,000 Quiz
No one has won the big million-dollar prize yet, perhaps because the host, Nick Parsons, asks the most complicated questions on TV. Most contestants leave with nothing.

Star in My Car
Neil Smith drives around Los Angeles in a big car. Inside is a camera and a celebrity! They sing along to the radio. It's not as boring as it sounds. Neil asks much more interesting questions than other presenters ask.

The Sound
Every week, contestants get the chance to sing in front of celebrity singers. Some contestants have a lot of talent – but many don't. The winner of the show gets a recording contract.

Nutty Antiques
This comedy is about a group of people who work in a store, selling old furniture. It's far funnier than anything else on TV. The best character is Mrs. Macaroon, the cleaner, who breaks everything.

I Want to Go Home!
Ten celebrities are on an island in the middle of nowhere with no electricity and no phones! They have to find their own food and cook it. It's great to see them argue – and they often do! All the celebrities want to go home, but you can go online and vote for the celebrity you want to keep on the island!

Old Bernard's Balloon
This is easily the best kid's show on TV. Bernard tells stories about how he flies around in a balloon, meeting his friends Russell the dragon and Jack the parrot. It's beautifully animated.



IV. Rewrite the sentences so that they have the same meaning.

- 0. Tom is a bad cook compared to you. (much)
You are a much better cook than Tom.
- 1. Chips are healthier than vegetables. (far)
Vegetables _____.
- 2. This film is definitely more boring than the book. (a lot)
The book _____.
- 3. It is cloudier today than it was yesterday. (a bit)
The weather _____.
- 4. My tablet is a lot newer than your computer. (much)
Your computer _____.
- 5. Mary is 1.37m and Tia is 1.35m. (a bit)
Tia _____.

COMPARATIVES - CROSSWORD

LOOK AT THE PICTURES AND FILL IN THE CROSSWORD PUZZLE. USE THE COMPARATIVE.

THE HIDDEN WORD IS _____



Friday

I. Cut the questions. Paste in an extra paper and answer each of them.

16 Question Strips

FIRST CONDITIONAL



- What will you do ***if you can't sleep tonight?***
- ***If your TV breaks next week,*** what will you do?
- How will you feel ***if you fail your next test?***
- ***If you get lots of homework,*** how will you feel?
- What will your teacher say ***if you are late tomorrow?***
- ***If you feel bored next Saturday,*** what will you do?
- What will you eat ***if you are hungry at midnight tonight?***
- ***If you want to relax after class,*** what will you watch on TV?
- What medicine will you take ***if you catch a cold next week?***
- ***If you decide to eat out,*** which restaurant will you go to?
- When will you go to bed ***if you are really tired tonight?***
- ***If you don't eat breakfast tomorrow,*** will you feel hungry?
- Will you ask our teacher for help ***if you have a question?***
- ***If you have some free time on Saturday,*** will you study more?
- Will you get a cat ***if you decide to get a new pet?***
- ***If it rains tomorrow,*** will you bring an umbrella?



II. Use the phrases from the list to complete each sentence.

0. Can I get you something to eat?
1. If I _____, I want to visit Argentina when I'm in South America.
2. He _____ when his soccer team wins.
3. Her driving _____ since she passed her driving test.
4. I _____ really late yesterday.
5. I'm late! I need to _____ to class.

Get	(you)
something	
get the chance	
get home	
get back	
get excited	
get better	

III. Circle the correct words.

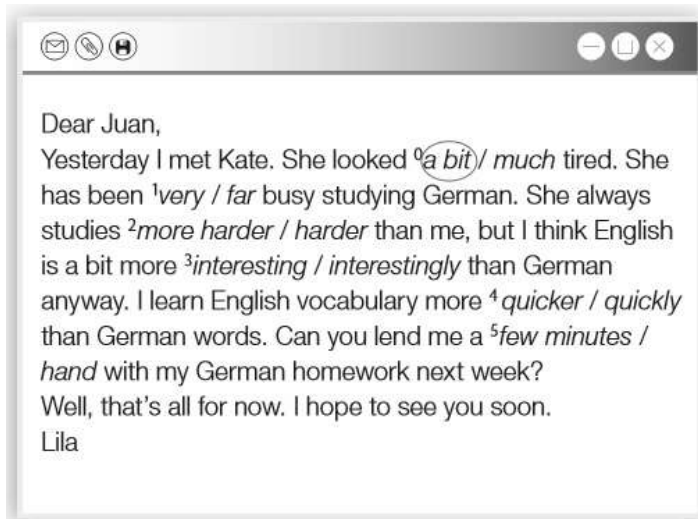

Anexo 2

Monday

BIM II

Week 2

I. Circle the correct words

1. An increase in the amount of gases in the atmosphere may be the cause of *deforestation* / *global warming* / *litter*.
2. We are not doing enough to protect the environment from endangered species / pollution / threat.
3. To protect the world's resources we shouldn't waste / litter / melt water and electricity.
4. A lot of rain can cause terrible smog / litter / floods.
5. Dinosaurs live only in films, they are an *endangered* / *extinct* / *waste* species.



ii. Complete the sentences. Use the first conditional of the verbs.

- Unless you _____ (be) in a hurry, we _____ (walk) to the station.
- You _____ (not feel) ill if you _____ (not eat) so many sweets.
- _____ (you / look after) my dog if _____ (go) on holiday.
- We _____ (arrive) at 10.00 unless our train _____ (be) late.
- If you _____ (lend) me the money, I _____ (come) to the concert.

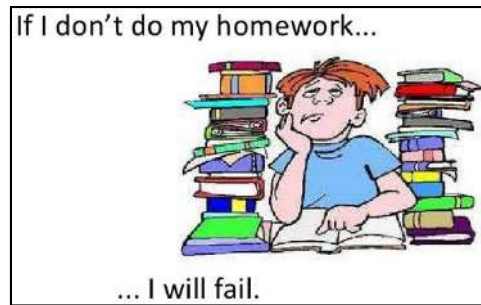

iii. Rewrite the sentences. Use *unless* and keep the same meaning.

0. If you don't eat breakfast, you'll be hungry.

_____.

1. Dad won't let you go out if don't apologize.

_____.

2. If we don't save energy, we'll run out.

_____.

3. If she doesn't pass the exam, she won't go to university.

_____.

4. I'll go out on Friday if I don't have homework.

_____.

5. Don't interrupt me if you don't want to be rude.

_____.



Tuesday

i. Write sentences. Use will or might / may.

1. not / pass his driving test (certainty)

_____.



2. visit my cousin / in France (possibility)

_____.

3. not / rain later / blue sky (possibility)

_____.

4. be / food at the party (certainly)

_____.

5. see / you later (certainly)

_____.

II. Find and correct the mistakes in each sentence.

0. I may not to finish this homework.

I may not finish this homework.

1. May you be at the party?

_____.

2. She'll be late unless she will leave now.

_____.

3. If he won't see me, I'll shout.

_____.

4. If he doesn't call, what do you do?

_____.

5. They might to buy me a present.

_____.

III. Complete the sentences with WILL or WON'T

0. This is a present for mum. I'm sure she will like it.
1. If there are no rules to reduce overfishing, more fish _____ definitely disappear forever.
2. My parents left yesterday for a two-week holiday, so they _____ be here tomorrow.
3. Come back early or you _____ get up on time.
4. If we do not protect rhinos, we _____ see any of them in the near future.
5. Do you think people _____ live on other planets in the future?



Wednesday

I. Read the article

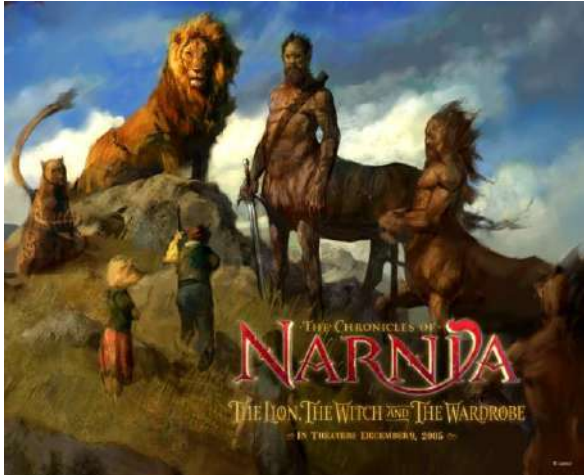

The Lion, the Witch and the Wardrobe tells the story of the Pevensie children – Peter, Susan, Edmund and Lucy – and their first adventures in the magical land of Narnia. The story begins during World War II in England. Because of the bombs in London, the children have to go and stay with their strange uncle in the country. The house he lives in is much bigger than their home in London, with many empty rooms. There is a big old wardrobe in

one of the rooms. While they are playing a game of hide-and-seek, Lucy, the youngest Pevensie, hides inside the wardrobe. She discovers that it isn't a normal wardrobe at all. It is a door to a snowy place in a forest. The place is silent and deserted and, the strangest thing of all, there is a lamp post in the middle of the trees. Lucy tells her brothers and sister about her adventure, and soon all four Pevensie children travel through the wardrobe to the land on the other side. They discover it is called Narnia and it is a magical place with talking animals and other strange creatures. It is cold and snowy because a witch's spell makes it endless winter. Because of a Narnian story/legend about four children who come from another land to help the Narnians, the four children become the kings and queens of the land. They have to lead a fight against the evil forces that are controlling Narnia. With the help of Aslan, a talking lion and the most powerful creature in the land, they win the fight against the witch and her evil creatures. Spring returns to Narnia, and it is a happy place again. Unfortunately, the Pevensies have to return to the "real" world and leave their new friends behind. But all four agree that discovering Narnia is the most amazing experience of their lives.

II. Underline the correct choice.

1. The children go to the country because of the weather / the war.
2. There are three / four Pevensie children.



3. The children play hide-and-seeK in the house / the woods.
4. The wardrobe leads to another house / land.
5. It is always winter in Narnia because of a witch / the children.
6. The children become soldiers / rulers in Narnia.
7. Aslan is a lion / a man.
8. The witch and her creatures win / lose the fight against the Narnians.

III. Complete the story outline. Use one or two words.

The Pevensie children go from (1) _____ to the country during (2) _____. They stay in (3) _____ house. It has many (4) _____. During a game of hide and seek, the (5) _____ Pevensie discovers a wardrobe that is really a (6) _____ to a place called Narnia. The four Pevensies become (7) _____ and queens of Narnia and they lead the fight against an evil witch. In the end they (8) _____ the fight.

IV. Answer the questions. Use complete sentences.

1. Why do the Pevensie children go from London to the country?

2. Who do they stay with?

3. What are they doing when they find the wardrobe?

4. What is the name of the magical place behind the wardrobe?

5. What makes it a magical place?

6. What do the Pevensies become there?

7. What do they have to do there?

8. Who helps them?

9. What is the result of their effort?



10. Where do they go in

Thursday

I. Match the parts of the conversation.

- 0. Why don't you disconnect your mobile a
- 1. You should reuse cans, _____
- 2. Leaving things on standby is _____
- 3. My mobile battery is getting old. _____
- 4. It is possible to recycle glass _____
- 5. If you keep lights on all night, _____

- a. ~~when you aren't using it?~~
- b. I need to charge it twice a day.
- c. they make good pen holders for your desk!
- d. a waste of energy
- e. into bottles, jars and also bricks.
- f. you'll waste a lot of energy

II. Complete the text with the words in the list.

saving	global warming	rubbish
melt	extinct	laws

~~Global warming~~ is a problem for all of us. Our environment is important and if we don't look after it, the polar ice caps will _____ and animals will become _____ because they won't have homes. In many countries there are _____ to protect animals and the environment but we can also help by _____ energy and recycling our _____

III. Circle the correct words.

- 0. 'What about the weather tomorrow?'
' I don't know, it *will* / *may* rain'.
- 1. 'Can you give Tom a message?'
'I don't think I *will* / *might* see him tonight'
- 2. 'Are you coming to the party next Saturday?'
'I'm not sure. I *will* / *might* not be here'.



3. *We'll / We might* be at home. Come over in the afternoon and I'll show you the photos of my holiday.
4. I'm sure Mary *will / might* win the music competition – she's been practicing a lot and she plays really well.
5. It's not easy to choose a present for someone you don't know well. They *won't / mightn't* like it.

IV. Complete the sentences. Use the *First Conditional* of the verbs.

0. Mary won't go (not go) on the school trip if she isn't well.
1. _____ you _____ (give) Jane my message if you see her?
2. If we _____ (not use) cars, cities won't be so polluted.
3. If we _____ (not learn) to recycle properly, we will have problems in the future.
4. If you _____ (use) a glass of water when you brush your teeth, you'll save a lot of water.
5. What _____ (happen) if they keep cutting trees?

Friday

Count on me (Bruno Mars)

I. Listen to the song. Complete the definitions with the right words.

stuck - find out - mean to - in need - toss and turn - count on

1. If you _____, you keep moving around in bed and cannot sleep properly, for example because you are ill or worried.
2. If you _____ something _____, you learn something that you did not already know, especially by making a deliberate effort to do so.
3. If you _____ someone you rely on them to support you or help you.
4. If something _____ something _____ you, it is important to you in some way.
5. If someone is _____, he/she is in a difficult situation.
6. If you are _____ you are unable to escape from a bad or boring situation.



II. Complete the sentences with the correct form of the verbs and the words or phrases represented by the pictures.

If you ever _____ (find) yourself stuck in the middle of the



I _____ the world to find you .



If you ever _____ (find) yourself lost in the dark and you



I _____ (be) the _____ to guide you.



Find out what we're made of when we are called to help our friends in need.

You can count on me like one two three

I _____ (be) there

And I know when I _____ (need) it I can count on you like four three two

You _____ (be) there

'Cause that's what friends are supposed to do, oh yeah

Whoa, whoa Oh, oh Yeah, yeah

If you _____ and you _____ and you just



I _____ beside you



And if you ever _____ how much you really mean to me



_____ I _____ (remind) you



Ooh

Find out what we're made of when we are called to help our friends in need.

You can count on me like one two three

I _____ (be) there

And I know when I _____ (need) it I can count on you like four three two

You _____ (be) there

'Cause that's what friends are supposed to do, oh yeah

Oh, oh Yeah, yeah

You _____ always _____ (have) my _____ when you



_____  _____ (let go)

Never _____

You know you can count on me like one two three

I _____ (be) there

And I know when I _____ (need) it I can count on you like four three two

And you _____ (be) there

'Cause that's what friends are supposed to do, oh yeah

Oh, oh

You can count on me 'cause I can count on you.

III. Match the beginnings of the sentences to the correct endings.

IF- CLAUSE

(Condition – possible in the future)

MAIN CLAUSE

(Result)

If you ever find yourself stuck in the middle of the sea,
 If you ever find yourself lost in the dark and you can't see,
 If you are tossing and you're turning and you just can't fall asleep,
 If you ever forget how much you really mean to me,

I'll sing a song beside you.
 every day I will remind you.
 I'll sail the world to find you.
 I'll be the light to guide you.

We use the **First Conditional** to talk about situations that have a realistic chance of happening in the future.

Anexo 3

Monday

Week 1

BIM III

I. Complete the sentences. Use the second conditional form of the verbs.

- If I _____ (win) the lottery, I'd be very happy.
- If I _____ (go) on holiday, I would go to the Bahamas.
- If I _____ (not live) here, I'd live in Florence.
- I _____ (not download) that programme if I were you.
- How you _____ (feel) if everybody _____ (forget) your birthday?

II. Complete the text with the words in the list.

~~used~~ | up and down | wish | would had | laboratory

When I lived in London, I used to go to the zoo in Regent's Park every month, but now I work
 in a _____ at the hospital and I don't have time. I _____ I wasn't so busy.
 If I _____ more time, I _____ take my dog there so he could run
 _____ the park.

III. Circle the correct words.

- While Newton **was relaxing / relaxed** under a tree, an apple fell on his head.
- As Archimedes was getting out of the bath, he **was realising / realised** that the water went down.
- There was an explosion while Apollo 13 **was flying / flew** to the Moon.
- The students **were working / worked** in the lab when the lights went off.
- I **was searching / searched** the web when I found an interesting science site.

I. Write questions. Use USED TO and the words.

0. you / play any sports

Did you use to play any sports?

1. you / take the bus to school

_____ ?

2. Tom / have short hair

_____ ?

3. your grandparents / have a television when they were young

_____ ?

4. you / go to bed early when you were younger

_____ ?

II. Choose the correct alternative.

1. I smoke, but now I have stopped.

a. used to b. use to c. am used to

2. That auditorium be a cinema.

a. uses to b. used to c. am used to

3. I like opera, but now I don't.

a. uses to b. used to c. am used to

4. I like western music, but now I do.

a. use to b. used to c. am used to

5. I always be afraid of the dark.

a. be use to b. is used to c. used to

III. Write sentences using I wish.

0 I have black hair. (blond) I wish I had blond hair.

1 I am shy. (not so shy) _____

2 I don't have enough free time. (more free time) _____

3 It rains all the time. (not rain) _____

4 I live in a village. (city) _____

5 I'm short. (taller) _____

READING

Last week, we asked you this question: What will life be like in 20 years' time? Here are some of your answers.

ANNA

There will be a lot more people in the world. It would be great if no one was hungry, and everyone had enough to eat. So, I think we will need to change our habits. We won't eat so much meat, because there won't be enough space for big animals. I think we'll eat insects instead of chickens or cows. But also, there won't be enough space for normal farms, so we will need to make tall towers and grow our vegetables inside them with special lights. It would be a very different type of farm from what we have today.

IVAN

Computers will be even more intelligent soon. Think about it. What would you do if a computer was able to do your job better than you? Well, soon, that's going to be true. Computers will drive all cars, so goodbye truck and taxi drivers! Machines will replace receptionists, and there won't be people making our shirts and jackets anymore. We will just make what we need with 3-D printers. We will need to train people who can program computers and write code. People who aren't learning to do these things now might have big problems in the future.

BARBARA

I read an article that the Internet will be everywhere. It's called "the Internet of things." Things will "talk" to other things. For example, your apartment will know when you are not there, and it will lock all the doors and switch off the lights for you. We will use smartphone apps to tell machines to water our plants outside when we are away. Your bathroom will know when you have no more toothpaste, and it will send a message to buy more. Your alarm clock will send messages to your coffee maker so you have hot coffee when you wake up. Your car will notify your house when you will arrive so that the house can adjust its temperature.

I. Read the article. Match the topics (a–h) to the people in the article (1–3).



- a) Food
- b) The home
- c) Clothes
- d) New buildings
- e) Gardens
- f) Shopping
- g) Education
- h) Work

II. Read the article again. Mark these sentences T (true) or F (false), or DS (doesn't say).

- 1. Anna thinks that people will eat different types of food in the future.
- 2. She says that we won't have farms.
- 3. Ivan thinks that most jobs will be the same in the future.
- 4. He knows how to program computers and write code.
- 5. He thinks we need to start learning now what we will need to do in the future.
- 6. Barbara says that we won't need technology much in the future.
- 7. She is worried about the future.

WRITING

I. Read the email invitation from a friend. Write a reply (100–125 words) saying that you would like to go, but can't. Use the ideas below to help you:

- You should do your homework before Friday morning.
- You would need to get permission from your parents.
- 9 p.m. is too late
- You are having your own party on Saturday at 7 p.m. at your house.

Hello,

We're organizing a party for Thursday night at my house. Would you like to come?

It's from 9 p.m. to midnight, and everyone will be there.

Write soon,

Alex

Friday

I. Complete the sentences. Use the second conditional.

o My parents work in a supermarket, so they are busy on Saturdays.

If my parents didn't work in a supermarket, they wouldn't be busy on Saturdays.



- 1 I don't have a job, so I don't buy clothes.
If I _____, I _____.
- 2 My car is very old, I spend a lot of money on it.
I _____ if it _____.
- 3 My sister doesn't study and her results are bad.
If my sister _____, her results _____.
- 4 The weather is awful, so we can't play outside.
If the weather _____, we _____.
- 5 I don't have a phone so I can't text friends.
If I _____, I _____.

II. Complete the sentences with your ideas. Use the second conditional.

- 0 If I were a famous scientist, I would fly to the moon.
- 1 If I had a private jet, _____
- 2 If I got lost in a big city, _____
- 3 The world would be a better place if _____
- 4 My schoolmates would be happier if _____
- 5 It would be fantastic if _____

III. Write sentences with your own ideas. Use I wish.

- 0 A scientist: I wish I could fly to the moon
- 1 A Maths teacher: I wish _____.
- 2 A person lost on a desert island: I wish _____.
- 3 An actor: I wish _____.
- 4 A contestant in a talent show: I wish _____.
- 5 An ill person: I wish _____.

Anexo 4

Monday

BIM IV

Week 4



I. Complete the sentences. Use the correct Passive tense.

1. A dangerous prisoner _____ (just catch) by the police.
2. My wallet _____ (find) on the bus yesterday – I'd left it there.
3. _____ your computer _____ (repair) right now?
4. The house _____ (not paint) for 20 years.
5. The offices _____ (clean) at 8.00 pm.

II. Complete the sentences with *job* or *work*.

1. A lot of young people are out of _____ in this country.
2. They have promised to create a lot of new _____.
3. I like my _____, it's hard but really interesting.
4. I'm glad you're happy with my _____ - I'm trying to do my best.

III. Complete the sentences. Use the past simple, past perfect simple or past perfect continuous.

0. Sara get dressed / go to work

After she had got dressed, Sara went to work.

1. Travis wait 2 hours / decide to go home

Tom _____.

2. Gianella think about it all night / knew what to do now.

Gianella _____.

3. the passengers / fly eight hours / reach New York.

After they _____.

4. John / drink a coffee / go back home.

After he _____.

5. all the players / warm-up / match start

Before the _____.

Tuesday

I. Match the part of the sentences

- 0 a I'll phone you
- 1 _____ Max left home early, walked for a while,



- 2 ____ I'm going to learn how to swim
- 3 ____ I'll have a party
- 4 ____ You should tell your father
- 5 ____ The competition won't start

- a. ~~as soon as I get to the hotel.~~
- b. then he took the bus to school.
- c. until it stops raining.
- d. as soon as you can.
- e. when I get my first salary.
- f. while I'm at the seaside.

II. Complete the questions. Use the present passive of the verbs.

0 **Is coffee grown in Italy?**

- 1 _____ Mercedes cars _____ (produce) in France?
- 2 _____ Swahili _____ (speak) in Asia?
- 3 _____ surfboards _____ (make) of metal?
- 4 _____ your job _____ (pay) well?
- 5 _____ kangaroos _____ (find) in Europe?

III. Complete the sentences. Use the past perfect of the verbs.

0 **I'd been (be) at the bus stop for half an hour when the bus arrived**

- 1 Marvin stayed at home for two weeks after he _____ (have) the operation.
- 2 We thought we were late, but the film _____ (not start).
- 3 I thought I _____ (lose) my wallet, then I found it under the sofa.
- 4 Marta got very angry because Hugo _____ (not stop) at the red light.
- 5 When we got to the bank, it _____ (already / close).



Wednesday

READING

I. Read the article. Match the information (1–8) with the numbers (a–h).

The best jobs

If you want to be healthy, one thing you need to do is choose a job that you love. After all, people spend a lot of their time working. But who are the happiest workers? Over 2,000 workers were interviewed, and here are the results. If you work with plants, you will be happy – 87% of people who work in gardens or with flowers love their careers. Florists – people who sell flowers – are at the top. Florists don't earn a lot of money, but they see beautiful things every day and meet a lot of people. Also, they can quickly see if they are successful. It's easy. If they have healthy flowers around them and happy customers, then they will know they have done a good job. This might be the most important thing of all and might explain why 79% of hairdressers also feel happy with their lives. They know if they've done a good job or not as soon as they have finished cutting someone's hair. However, only 62% of nurses, and 59% of teachers say that they are happy. Although they

work hard to make other people better, the results of this work are not seen so quickly. Or, they may never be seen. Another important thing is who you work for. Many florists or hairdressers are self-employed, meaning that they have their own company. Because of this, they don't have to worry about making their boss happy or being promoted. Research shows that over 90% of self-employed people are happy because they are able to control their own day, but only 54% of people who work for someone else are happy. Money doesn't always make you happy, of course. Research shows that people with a salary of more than \$78,000 a year are the unhappiest. Near the bottom of the list are IT workers. Despite their large salaries, only 48% love their jobs. Then, we have bankers – only 44% enjoy what they do. It seems that choosing a job because of what you might earn isn't always a good idea.

- | | |
|---|----------|
| 1. Happy teachers () | a) 44% |
| 2. Happy hairdressers (f) | b) 48% |
| 3. Happy bankers () | c) 54% |
| 4. Happy florists () | d) 59% |
| 5. Happy IT workers () | e) 62% |
| 6. The number of people who were questioned () | f) 79% |
| 7. Happy nurses () | g) 87% |
| 8. People who work for someone else and are happy () | h) 2,000 |



II. Read the article again. Mark these sentences T (true), F (false), or DS (doesn't say).

- 1. Florists are happy, but it's not a job for people who want to be rich. _____
- 2. People are happier when they can see if they have been successful or not. _____
- 3. Nurses and teachers always know if they have done a good job. _____
- 4. People who have their own company usually work long hours. _____
- 5. People who work for someone else are happier than self-employed workers. _____
- 6. People who have low pay are often happy _____
- 7. The unhappiest people are IT workers. _____

Thursday

WRITING

III. Write a paragraph (100–125 words) about jobs. Use the questions below to help you, and use the past perfect if possible.

When you were a child, what did you want to be?

Did you change your mind?

When/Why did you change your mind?

What characteristics of a job are important to you?



Friday

I. Complete the sentences. Use the past perfect simple of the verbs in the list

speak | not recover | go | eat | turn | meet

- 0 After **she had spoken** to the doctors, Jane understood that her father's illness was nothing serious.
- 1 I remembered that I _____ him before at a school sports competition.
- 2 After they _____ for a run they had a drink.
- 3 _____ you already _____ before the guests arrived?
- 4 Kate had to stay in bed two more days because _____ from her cold.
- 5 We _____ just _____ the corner when we saw a group of people.

II. Complete the text with either the past simple or the past perfect form of the verbs.

arrive | get | go | leave | eat | not go

When I **got** to the party, Tom 1. _____ already _____.
But, he 2. _____ home – he'd been taken to hospital. He 3. _____ some fish before
he 4. _____ at the party and felt very ill. I 5. _____ to the hospital to find him.

III. Complete the sentences with your ideas. Use the past perfect continuous.

- 0 The football ground was wet in the morning because it **had been raining** all night.
- 1 The children's bedroom was in a terrible mess because they _____.
- 2 Tom was late because he _____.
- 3 The children were dirty because they _____.
- 4 We were hungry because we _____.
- 5 Alice felt sick because he _____.



Inventario de actividades de Inglés (nivel: ADVANCED)
(Apoyo a la recuperación académica 2017)

Estimado estudiante:

Te proponemos el presente inventario de actividades como un recurso de apoyo para el proceso de recuperación académica que debes seguir durante el mes de enero de 2018. Te pedimos tener presente, respecto al inventario, lo siguiente:

- Ha sido elaborado de acuerdo con un temario anual, el cual considera los cuatro bimestres (25 % c/u).
- Las actividades que se presenta en él han sido tomadas de documentos de trabajo, libros del año escolar 2017 y de otras fuentes, pero que se ajustan a los contenidos del temario anual.
- Ha sido dosificado para ser desarrollado en cuatro semanas, de lunes a viernes, destinando para ello una hora diaria aproximadamente.
- El estudiante debe imprimir los documentos que serán desarrollados, archivados y presentados en un fólter manila tamaño oficio (incluir carátula), el mismo que será revisado y evaluado por los docentes responsables de la evaluación de recuperación, asignándole un peso de 25 % en el resultado final de la recuperación como "evaluación de portafolio". De hecho, si no lo presentases desarrollado, se te asignará la nota mínima en evaluación de portafolio.
- NOTA: Se adjunta hoja de respuestas para que al fin del trabajo pueda revisar su avance.
- Si los estudiantes requiriesen presentarse a la segunda oportunidad, podrán mejorar y volver a presentarlo desarrollado, prevaleciendo, en este caso, la segunda calificación. Si no lo hiciesen, mantendrán la calificación obtenida en la primera ocasión.
- En la tabla de control diario, el padre de familia debe firmar para apoyar y controlar el avance diario del estudiante en su desarrollo.
- No hemos incluido una calendarización específica para su desarrollo (fechas de inicio y fin), asumiendo que cada estudiante lo hará en coordinación con sus padres, considerando la realidad particular y los planes de la familia. En todo caso, el trabajo ha sido previsto para cuatro semanas.
- La primera oportunidad de evaluación será a fines de enero. La presentación del portafolio (inventario desarrollado) es obligatoria desde la primera oportunidad de evaluación.

WEEK	UNIT	TOPIC		
		Nº	GRAMMAR	VOCABULARY
1	4 DILEMMAS	1	FIRST CONDITIONAL	BEING HONEST
		2	SECOND CONDITIONAL	MAKING A DECISION
2	6 HOW DO THEY DO IT?	1	PRESENT AND PAST PASSIVE	EXTREME ADJECTIVES
		2	FUTURE AND PRESENT PERFECT PASSIVE	MODIFIERS
3	8 IT'S A CRIME	1	REPORTED SPEECH	CRIME
		2	REPORTED QUESTIONS	REPORTING VERBS
4	10 MONEY	1	FUTURE CONTINUOUS	MONEY AND VALUE
		2	FUTURE PERFECT	JOBS AND WORK

	Tabla de firmas del padre de familia de control diario				
	Lunes 1 de enero	Martes 2 de enero	Miércoles 3 de enero	Jueves 4 de enero	Viernes 5 de enero
Semana 1					
	Lunes 8 de enero	Martes 9 de enero	Miércoles 10 de enero	Jueves 11 de enero	Viernes 12 de enero
Semana 2					
	Lunes 15 de enero	Martes 16 de enero	Miércoles 17 de enero	Jueves 18 de enero	Viernes 19 de enero
Semana 3					
	Lunes 22 de enero	Martes 23 de enero	Miércoles 24 de enero	Jueves 25 de enero	Viernes 26 de enero
Semana 4					

ANEXOS



WEEK 1

MONDAY

Anexo 1

I. Read the text and circle the correct answer for each number.

THE NETHERLANDS

Welcome to the Netherlands, a tiny country that only extends, at its broadest, 312 km north to south, and 264 km east to west - (0) **ALTHOUGH** the land area increases slightly each year as a (1) _____ of continuous land reclamation and drainage. With a lot of heart and much to offer, 'Holland,' as it is (2) _____ known to most of us abroad - a name stemming (3) _____ its once most prominent provinces - has more going on per kilometer than most countries, and more English-speaking natives. You'll be impressed by its (4) _____ cities and charmed by its countryside and villages, full of contrasts. From the exciting variety (5) _____ offer, you could choose a romantic canal boat tour in Amsterdam, a Royal Tour by coach in The Hague, or a hydrofoil tour around the biggest harbour in the world - Rotterdam. In season you could visit the dazzling bulb fields, enjoy a full day on a boat, or take a bike tour through the pancake-flat countryside spiced with windmills. The possibilities are countless and the nationwide tourist office, which is on hand to give you information and (6) _____ reservations. You'll have (7) _____ language problems here, as the Dutch are true linguists and English is spoken here almost universally.

- | | | | |
|-----------------------------|-----------------|-----------------|--------------------|
| 0. A) so | B) despite | C) in spite of | D) although |
| 1. A) whole | B) consequently | C) rule | D) result |
| 2. A) regularly | B) occasionally | C) commonly | D) unusually |
| 3. A) in | B) from | C) on | D) of |
| 4. A) historic
historian | B) historical | C) historically | D) |
| 5. A) at
D) for | B) in | C) on | |
| 6. A) sit | B) catch | C) do | D) make |

7. A) few

B) a few

C) little

D) a

little

II. Read the text below and think of the word which fits each gap. Use only one word in each gap.

THE HISTORY OF PAPER

The history of paper is also the history of human culture and (0) **CIVILISATION**. The Egyptians, Greeks and Romans wrote on "papyrus", a paper-like material. Today's kind of paper was first (1) _____ and used in China. Paper was the most important carrier of information in the past. It was only with increasing paper production that the transfer of (2) _____, education and information to a larger portion of (3) _____ became possible.

With paper emperors were able to administrate large empires more easily. In former times paper was a (4) _____ product, and paper making an art - an art that was often kept secret because of the outstanding (5) _____ of the product. Today paper has changed from a rare artisan material to a commodity product, with a high (6) _____ value in communication, in educational, artistic, hygienic, sanitary, and technical applications. Nobody can imagine a word without paper. A large (7) _____ of paper grades are produced to suit the special (8) _____ of each application.

CIVILISE

CARRY

KNOW

SOCIAL

VALUE

ADVANCE

PRACTISE

VARY

REQUIRE

III. Circle the correct words.

0. Have you ever *said* / *told* a lie?

1. You should *do* / *be* the right thing and tell the truth.

2. Simon *opened* / *owned* up to breaking the window.

3. There's no point trying to *cheat* / *hide* the truth.

4. Did you think you would *get* / *be* away with stealing that money?

5. I have never *hidden* / *cheated* in a test in my life.

TUESDAY

IV. Complete the conversation with the words in the list.

reconsidering | bad | thought | right | made | come

MARTA: I still don't know what to study at university.

SAM: I thought you'd already (0) **made** up your mind about that? You (1) _____ long and hard and decided you wanted to study History.

MARTA: I know, but I'm (2) _____ that now.

SAM: You don't think it's the (3) _____ decision?

MARTA: No, I think it was a (4) _____ decision. I don't really enjoy History.

SAM: Well, you'd better (5) _____ to a decision before the end of the year!

V. Circle the correct words to complete the dialogue.

MARK: Sara, if you (0) **see / will** Tim will you tell him I'll meet him at the sports centre at 6 o'clock?

SARA: Sure, I (1) **tell / 'll tell** him if I see him. But why don't you just text him?

MARK: I (2) **'d text / 'll text** him if he had a mobile phone, but he hasn't.

SARA: Has he lost another one? His mum said she (3) **won't / wouldn't** buy him any more if he did that again.

MARK: I know. I don't think he's going to tell her. She'll be really angry if he (4) **does / did!**

SARA: If I lost as many phones as Tim, I (5) **won't want / wouldn't** want another one! They're too expensive!

VI. Choose the correct response for each of the sentences.

0. If his nose were smaller, he _____ very handsome.

- a) would be
 was

1. I would come if I _____ a car.

- a) would have
b) had

2. If she _____, she would tell him.

- a) knows
b) knew

3. If his parents didn't give him money, he _____ so much.

- a) wouldn't go out
b) didn't go out

4. If she _____ me, she would have told me.

- a) didn't believe
b) wouldn't believe

5. He wouldn't say that if he _____ it.
 a) wouldn't mean
 b) didn't mean
6. I _____ on a trip around the world if I won the lottery.
 a) would go
 b) will go
7. I _____ that if I were you.
 a) will not do
 b) would not do
8. If these walls _____ thicker, we wouldn't hear the neighbors.
 a) would be
 b) were
9. If I were a millionaire, _____ a mansion.
 a) I'd buy
 b) I'm going to buy

VII. Complete the second sentence so that it has a similar meaning to the first sentence, using the word given. Do not change the word given. You must use between two and five words, including the word given.

<p>0. Susan and Frank don't like each other. WELL</p> <p>Susan and Frank don't GET ON WELL with each other.</p>
<p>1. Was it necessary for her to spend so much money on it? HAVE</p> <p>Did _____ spend so much money on it?</p>
<p>2. It's possible that he hasn't been informed about his uncle's death. MIGHT</p> <p>He _____ informed about his uncle's death</p>
<p>3. Why did you sell such a great car? MADE</p> <p>What _____ such a great car?</p>
<p>4. 'What do you think of the new health centre?' ASKED</p> <p>She _____ of the new health centre.</p>

WEDNESDAY

VIII. Complete the sentences with the correct form of the words in the list.

come | forget | visit | ask | bake | not give

0. If you **had forgotten** to take your umbrella, you'd have got very wet!
1. I'd have had a great weekend if the teacher _____ us so much homework.
2. If I'd known, you were coming I _____ a cake.
3. You would have enjoyed yourself if you _____ with us to the concert.
4. If we'd had more time, we _____ more tourist sights.
5. Sam would have lent you the money if you _____ him.

IX. For questions 1-7, read the text below and think of the word which fits each gap. Use only one word in each gap.

CATS

Cats of all kinds are present in the legends, religion, mythology, and history of (0) **MANY** different cultures. Cave paintings created by early humans display different types of wild cats (1) _____ are now extinct, or no longer around. Many of these great beasts saw humans as food, but were hunted by humans in return. Cats similar (2) _____ the ones kept as pets today started showing up in artwork thousands of years ago. For example, the ancient Egyptians believed cats were the sacred, or special, animal of a goddess named Bast. They believed that Bast often appeared as a cat, so many ancient Egyptians respected and honoured cats and kittens. (3) _____, other cultures feared cats or thought that they brought illnesses and bad luck. Today, with millions kept as pets in homes around the world, cats have become important members of many families. No one knows for sure when or (4) _____ cats became very popular household pets. It's possible that people noticed how cats hunted mice and rats, (5) _____ they set food and milk out to keep the cats near their homes. This helped to prevent (6) _____ many of these rodents (7) _____ coming into homes and eating people's food or spreading sickness.

X. Circle the correct words.

0. If the baby wants more milk, she **'ll / 'd cry** for it.
1. If I was a teacher, I **won't / wouldn't** give homework.
2. What will you do if the bank **is / was** closed?
3. What would you do if someone **steals / stole** your phone?

4. I **'ll / 'd** get you a drink if you're thirsty.
5. If she **needs / needed** your help, she'd email you

XI. Complete the sentences with the correct form of the verbs.

0. If I **WERE** (be) you, I **WOULD GET** (get) a new job.
1. If he _____ (be) younger, he _____ (travel) more.
2. If we _____ (not/be) friends, I _____ (be) angry with you.
3. If I _____ (have) enough money, I _____ (buy) a big house.
4. If she _____ (not/be) always so late, she _____ (be) promoted.
5. If we _____ (win) the lottery, we _____ (travel) the world.
6. If you _____ (have) a better job, we _____ (be) able to buy a new.
7. If I _____ (speak) perfect English, I _____ (have) a good job.
8. If we _____ (live) in Mexico, I _____ (speak) Spanish.
9. If she _____ (pass) the exam, she _____ (be) able to enter university.
10. She _____ (be) happier if she _____ (have) more friends.
11. We _____ (buy) a house if we _____ (decide) to stay here.
12. They _____ (have) more money if they _____ (not/buy) so many clothes.
13. We _____ (come) to dinner if we _____ (have) time.
14. She _____ (call) him if she _____ (have) his number.
15. They _____ (go) to Spain on holiday if they _____ (like) hot weather.

XII. Match the parts of the sentences.

- | | |
|--------------------------------|--------------|
| 0. I'll text you | <u> C </u> |
| 1. Please don't start eating | _____ |
| 2. What are you going to do | _____ |
| 3. Don't give her your notes | _____ |
| 4. He'll be angry | _____ |
| 5. They are allowed to go home | _____ |

- A. when you get home tonight?
- B. if he doesn't win this race.
- C. as soon as I get there.
- D. unless she asks for them.
- E. as soon as they've finished this exercise.
- F. until I get home.

THURSDAY

XIII. Complete the sentences. Use your own ideas.

0. If I had been born in China, I' d be able to speak Chinese .
1. I' d have been very angry if _____ .
2. If it had snowed yesterday, _____ .
3. I' d have laughed a lot if _____ .
4. My teacher would have been happy if _____ .
5. If I had gone to bed at 1 a.m. last night, _____ .

XIV. Complete the sentences with the correct forms of the verbs.

study | have | would | can | live | not be

0. It's freezing today. If only I had a warm coat.
1. I wish my brother _____ stop taking my stuff.
2. If only we _____ in a bigger apartment.
3. I wish I _____ visiting my aunt.
4. If only I _____ harder for the exam.
5. I wish I _____ go on holiday.

XV. Read the text and circle the correct answer for each number.

THE STORY OF GOLD

The story of gold is an adventure involving kings, queens, pirates, explorers, conquerors, and the native peoples they conquered. Throughout history, gold has woven a magic spell over those it touched. Gold is beautiful and rare; a soft shiny metal that can be moulded into many (0) SHAPES. It has been used for money, jewellery, and to decorate special buildings such (1) _____ palaces and places of worship. (2) _____ the precious metal was discovered, prospectors rushed to mine it, starting new cities and countries as they went. Gold and the people who love it have helped shape the world we live (3) _____ today. Gold is one of many elements, or substances that cannot be changed by normal chemical means, that are found in the Earth's crust. Gold has a warm, sunny colour and (5) _____ it does not react (5) _____ air, water, and most chemicals, its shine never fades. In its natural (6) _____ gold is soft and easily shaped. When heated to 1,062 Celsius it melts and can be poured into molds to form coins, gold bars, and other objects. Stories have been told, movies

(7) _____ and legends born about the discovery of the world's great gold deposits. It is a saga of dreams, greed, ambition and exploration.

- | | | | |
|---------------|-------------|-------------|-------------|
| 0. A) formats | B) outlines | C) shapes | D) lines |
| 1. A) as | B) like | C) many | D) to |
| 2. A) Whoever | B) However | C) Forever | D) Wherever |
| 3. A) at | B) in | C) for | D) on |
| 4. A) yet | B) despite | C) because | D) so |
| 5. A) with | B) in | C) of | D) at |
| 6. A) estate | B) stage | C) state | D) position |
| 7. A) done | B) made | C) composed | D) built |

FRIDAY

XVI. Read the story. Then answer the questions below.



“The Mini Problem”

Lily's anger could not have been more **palpable**.

She awakened Christmas morning and, along with her brother, ran down to see the gifts under the tree.

In the living room sat a magnificent mini bike. It was red with a pearly white gas tank and side panels. For a brief moment, Lily was filled with what seemed like **insurmountable** excitement. She couldn't imagine anything better than getting that bike. Then, her eyes caught sight of a baby doll sitting on the couch with a huge bow.

She knew. She knew that the mini bike belonged to her brother and that she had been **relegated** to that doll. It was par for the course.

Tommy always got cool things: skateboards, gliders, science kits. The mini bike was just the latest cool thing.

Lily always got the boring gifts: a doll with a gown, a doll with a tutu, a doll with a puppy. This doll seemed unusually blah. The doll wore a petticoat. The doll had short, straight black hair.

Tommy had seen that mini-bike in the front window of Moore's Bike Shop, but hadn't Lily too? Both had begged for the bike. Both had said it was the only thing they wanted for Christmas. Hadn't Lily asked for it with as much **fervor** as her twin brother?

Tommy's eyes grew wide at the sight of the bike he knew was his—no doll for him. He ran into his parents' room and jumped excitedly on the bed.

“Thank you, Mama! Thank you, Papa!” he yelled.

Meanwhile Lily simmered in the other room. She was furious. She was enraged. She was **incensed**. It took a while for anyone to even realize she was missing.

“What’s wrong, Lil?” Papa asked. “Did you see your pretty doll?” “I saw it,” she said sulkily.

“What’s wrong?” asked Mama.

Silence. Lily’s jaw was fixed. Her hands clenched. Her whole body trembled.

“Oh, Mama, you know Lily is never excited by presents!” her brother laughed. “Come out and watch me ride!”

And so they did.

1) In the beginning of the story, Lily's anger was described as palpable because it was:

- A. unusual
- B. irrational
- C. difficult to understand
- D. easy to feel

2) As used in the beginning of the story, which is the best antonym for insurmountable?

- A. sane
- B. phony
- C. unjustified
- D. surpassable

3) As used in the beginning of the story, which best describes the act of being relegated?

- A. A star athlete is given a coveted award.
- B. A disobedient dog is put in the garage to sleep.
- C. After being tested; swimmers are put into groups according to their ability levels.
- D. The birthday boy is taken to his favorite restaurant.

4) As used in the beginning of the story, the expression par for the course implies that something

- A. is to be expected
- B. cannot be undone
- C. is sure to cause anger
- D. was meant to be hurtful

5) What is ironic about the title of this passage?

- A. Lily has a big problem.
- B. Tommy is perfectly happy.
- C. Lily does not get a mini bike.
- D. Lily’s parents do not realize there is actually a problem.

6) What could the author have written if she wanted to show Lily taking steps to improve her situation?

- A. a scene with Lily storming out of the house
- B. a description of Lily getting to ride the mini bike first
- C. a paragraph describing Lily pretending to appreciate the doll
- D. a dialogue with Lily explaining to her family why she was so angry

7) As used in the middle of the story, which is the best antonym for fervor?

- A. gluttony
- B. indifference
- C. politeness

D. passion

8) In paragraph 6, the author most likely repeats the word "doll" to

- A. highlight how extravagant the dolls were
- B. juxtapose the number of dolls with just one mini bike
- C. emphasize how common this gift had become for Lily
- D. make it clear that the doll she got this Christmas was the worst of all

9) As used at the end of the story, which is the best antonym for incensed?

- A. pleased
- B. annoyed
- C. patient
- D. indignant

MONDAY

WEEK 2

I. Read the text below and think of the word which fits each gap. Use only one word in each gap.

ABOUT FISH AND AQUARIUMS

There are more than 200,000 species of fish inhabiting many (0) **DIFFERENT** waters. New species of fish are discovered every year. From the deepest part of the seas thousands of feet down in total (1) _____, to the beautiful aqua-blue waters of the coral reefs, to the streams, lakes, and ponds of freshwater found throughout the world, fish have adapted an incredible variety of life-forms, styles, and (2) _____. The group of aquatic animals we call fishes has evolved for over 400 million years to be the most (3) _____ and diverse of the major vertebrate groups. Forty-one percent of the world's fish species inhabit only fresh water. This is pretty (4) _____ considering that fresh water covers only 1 percent of the world's surface. As you probably already know salt water covers 70 percent of the earth's surface. So the number and (5) _____ of fresh water species to marine or saltwater species is all the more mind-boggling. While they inhabit the smallest amount of water, they have, in fact, adapted to a much (6) _____ range of habitats and to a greater variety of water conditions. Let's take a closer look at the unique adaptations of fish that have allowed them to live so (7) _____ in the medium we call water.

DIFFER

DARK

BEHAVE

NUMBER

AMAZE

VARY

WIDE

SUCCESS

II. Put the adjectives

fantastic
delighted
big |

EXTREME	GRADABLE
_____	_____
_____	_____
_____	_____
_____	_____

into the correct column.

| tiny | small |
| funny | happy |
hilarious

III. Complete the text with the words in the list.

nice | happy | huge | fantastic | tiny | amazing

I've just returned from a week-long trip to the USA – it was absolutely (0) **fantastic**. We hired a very (1) _____ car from the airport in New York and we drove about 100 miles every day. Of course, the USA is an absolutely (2) _____ country, so we only saw a (3) _____ part of it – but what we did see was absolutely (4) _____. I'm really (5) _____ we went!



PASSIVE VOICE

TUESDAY

IV. Complete the sentences. Use the correct form of the present passive.

1. This TV programme **is shown** (show) every Saturday evening.

TENSE	ACTIVE	PASSIVE
Present Simple	They speak German in Austria.	German is spoken in Austria.
Present Continuous	They are planting some trees.	Some trees are being planted .
Present Perfect	Someone has eaten my muffin.	My muffin has been eaten .
Past Simple	They closed the road for a day.	The road was closed for a day.
Past Continuous	He was not feeding his dogs.	His dogs were not being fed .
Past Perfect	Someone had put out the fire before the fire brigade arrived.	The fire had been put out before the fire brigade arrived.
Future Simple	They will fine you for littering.	You will be fined for littering.
Future with 'be going to'	They are going to raise taxes.	Taxes are going to be raised .
Modal verbs	You can solve the problem.	The problem can be solved .

2. Students at my school _____ (not teach) how to play musical instruments.
3. The front door _____ (lock) every night at 11 o'clock.
4. Our old car _____ (not use) very much anymore.
5. My best photographs _____ (display) on the wall in the hallway.

6. The windows _____ (clean) twice a month.

V. Complete the sentences. Use the correct form of the passive.

- 0. Maria was **TOLD** to stop singing. (tell)
- 1. They were _____ by the ending. (surprise)
- 2. Michael was _____ by his grandparents. (raise)
- 3. This house was _____ by a famous architect. (design)
- 4. The child was _____ up by his father. (pick up)
- 5. The bank robbers were never _____. (catch)
- 6. This book was _____ by Ernest Hemingway. (write)
- 7. This stadium was _____ for the Olympic Games. (build)
- 8. My flight was _____ because of bad weather. (delay)
- 9. Classes were _____ by the principal. (cancel)

VI. Change these active sentences to passive.

- 0. My grandfather built this house in 1943.
This house was built in 1943 by my grandfather.
- 1. People speak Portuguese in Brazil.

- 2. I had cleaned all the windows before the storm.

- 3. He had written three books before 1867.

- 4. They are building a new stadium near the station.

- 5. The cleaner has cleaned the office.

VII. Complete the second sentence so that it has a similar meaning to the first sentence, using the word given. Do not change the word given. You must use between two and five words, including the word given.

<p>0. It wasn't Mark that you met in the shop. HAVE</p> <p>It <u>COULDN'T HAVE BEEN</u> Mark that you met in the shop.</p>
<p>1. She was just going to have her breakfast when the phone rang. ABOUT</p>

<p>She was just _____ breakfast when the phone rang.</p>
<p>2. Steve didn't manage to complete his work. FAILED</p> <p>Steve _____ his work.</p>
<p>3. How long has she been studying English? BEGIN</p> <p>When _____ studying English?</p>
<p>4. George wrote his last novel five years ago. WAS</p> <p>It _____ George wrote his last novel.</p>
<p>5. Nobody took any notice of his bad behaviour. ATTENTION</p> <p>Nobody _____ his bad behaviour.</p>

WEDNESDAY

VIII. Complete the sentences with the correct form of make or do.

0. Try not to **make** too much noise when you come home tonight.
1. I'll come out after I've _____ the housework.
2. The reason you don't understand it is because it doesn't _____ sense.
3. He needs to find a way to _____ money fast.
4. Marco _____ really well in his exams last year.
5. Will passengers please _____ their way to the departure lounge?

IX. Put the words in order to make sentences.

0. every / We / our windows / have / cleaned / month
We have our windows cleaned every month.
1. checked / got / by / my Dad / my homework / I

2. going to / her / She's / cut / tomorrow / hair / have

3. you / a tattoo / ever / Have / had / done ?

4. We / our house / had / painted / last summer

5. did / your bike / Where / get / you / fixed ?

X. For questions 1-7, read the text below and think of the word which fits each gap. Use only one word in each gap.

GUTENBERG

Before Gutenberg (1394 – 1468), all books had to be copied by hand. The so-called 'manuscripts' of medieval times were laboriously hand-written, usually by monks (0) WHO devoted years (1) _____ the work. Earlier attempts had been made to produce printing 'blocks'. The designs on playing cards (2) _____ example were carved from wooden blocks which were inked and then printed onto cards. There are even examples of whole pages in books being hand carved and printed. Gutenberg however came up with the idea of printing using, not whole page blocks, but letter blocks. (3) _____ he was a goldsmith (4) _____ trade, he knew how to mould metal into whatever shape was needed. He made thousands of tiny blocks of 'type', (5) _____ with a letter raised on it, which could be lined up and clamped into position in a 'forme' (page block). The type could be linked, paper laid on top, and the whole thing compressed by turning a handle. When released, the paper had the page printed on it. Years of work went into this invention. Gutenberg (6) _____ to make the letters, develop an ink which would cling to metal (most didn't), build the forme, and above (7) _____ find the money to do all this while not working as a goldsmith.

THURSDAY

XI. Underlined the correct words.

0. The burglars **are / were** arrested last night.
1. I **am / is** given \$10 pocket money every week.
2. **Was / Were** they beaten by many points?
3. Our chickens **aren't / isn't** kept in cages.
4. The experiment **was / were** done in the laboratory.
5. Lots of English words **is / are** spelled strangely.

XII. Complete the sentences with the future or present perfect passive form of the words in brackets.

0. This bicycle **hasn't been cleaned** (not clean) since last year.
1. Students _____ (not allow) to use calculators in the next test.
2. Lots of food _____ (prepare) for tonight's party already.
3. The children _____ (not give) their lunch money yet.
4. The final match _____ (play) next Saturday at 10 am.
5. A lot of questions still _____ (not answer).

XIII. Rewrite the sentences in the passive. Use by + agent if necessary.

0. The Queen opened the museum.

The museum was opened by the Queen.

1. They built this library in 1964.

2. They won't let you in if you're late.

3. My cat wakes me up every morning.

4. Nobody has fed the dog today.

5. My dad drove me to school this morning

XIV. Read the text and circle the correct answer for each number.

TOURISM

Tourism is one of the world's largest industries, and it is the fastest growing. It contributes over £50 billion to the economy annually, over £12 billion of it from overseas visitors. About 25 million overseas visitors (0) **COME TO** Britain each year. Tourism is one of the biggest employment (1)

_____ in the UK, too – it employs over 1.7 million people, which is more than in the construction or health service industries.

Around 20% of all new (2) _____ are in this industry. These figures are very impressive, but how do they translate (3) _____ job possibilities for you? There is room in this industry for all sorts of people, with different educational (4) _____ personal attributes, interests and career aims. A tourist is really a traveller – someone who (5) _____ a journey, usually for recreation, (6) _____ a holiday or sightseeing. (7) _____, tourism at its very simplest refers to the industry that provides travel and entertainment facilities for people away from their own homes.

0. A) come from **B) come to** C) come away with D) come down to
1. A) zones B) sections C) districts D) sectors
2. A) works B) jobs C) employments D) vocations
3. A) into B) from C) for D) at
4. A) in B) on C) for D) at
5. A) surroundings B) traditions C) backgrounds D) settings
6. A) makes B) does C) performs D) breaks
7. A) as B) such C) so D) like
8. A) although B) despite C) therefore D) because

FRIDAY

XV. Read the story. Then answer the questions below.

“City Girl”

I am a city girl at heart. I’ve never milked a cow – never wanted to. I was shocked when I attended my first “pig pickin’” after my husband and I moved to North Carolina from Boston. I had to **avert** my eyes from the huge pig, skin and head still on, splayed open across an oil drum that had been sawed in half lengthwise and fitted with hinges so it opened and closed.

This, I later learned, was called a “pig cooker.” Part of the pig’s insides were chopped up in a pan beside it and referred to as “barbecue.” Seeing all of this did not improve my appetite.

“Y’all in thuh country now, gul,” the host told me happily, apparently thrilled to be the one to indoctrinate me into country living.

When, at 8 months pregnant, I volunteered to chaperone my son’s strawberry-picking field trip, the other mothers looked at me strangely. I thought strawberries grew on tall bushes, not low to the ground. All that squatting sent me into early labor.



You should keep these incidents in mind in order to understand my attitude when I heard a “huge hurricane” was headed toward our town. I thought back to the snowstorms forecast during my days growing up in Philadelphia. The “20 inches” predicted by the weatherman never seemed to **materialize**.

The local newspaper ran a long checklist of things townspeople should get to prepare for the hurricane. My neighbor, Wayne, aware that I was new to town, made a point of giving me a copy of the list. I took a **cursory** glance and thought nothing more of it.

While my neighbors were running around taping their windows, buying fresh batteries, and prepping their generators, I was, quite **literally**, sitting in my glass house playing with the kids on the floor.

The rains started at 2 o’clock in the afternoon. To my amazement, this was exactly what the weatherman had predicted.

These were no ordinary rains, either. From my glass living room, I could no longer see the front lawn or the trees. The rain was as thick as a woolen curtain. By nightfall, my husband’s car had begun to float out of the driveway. The water started insidiously creeping up our front steps, overturning potted plants and benches in its wake.

“This is unbelievable!” I yelled. I reached for the phone to dial Wayne. He had been born and raised in these parts; surely he would know what to do.

“Wayne,” I said worriedly into the receiver. “The water is coming up our front steps. It’s almost to our door!”

“Ours, too,” he said, quite calmly, I thought, given the circumstances. “What should I do?”

“Put out your sandbags. It will keep the water out as long as it doesn’t get too high.”

“Sandbags?”

“You didn’t get any?” he asked in disbelief. “They were on the list.” No, I hadn’t.

1) What other title might fit this passage best?

- A. "An Urban Attitude"
- B. "Learning Hurricanes"
- C. "Picking Strawberries"
- D. "Snow Storms that Don't Come"

2) What seems to be the author's main purpose in the first four paragraphs of this passage?

- A. to let the reader know that the narrator went into early labor
- B. to let the reader know that the narrator does not like barbecue
- C. to let the reader know that the narrator is unfamiliar with country life
- D. to let the reader know that the narrator wants to move back to Boston

3) “I had to avert my eyes from the huge pig, skin and head still on, splayed open across half of an oil drum that had been sawed in half lengthwise.”

Which of the following is the best way to rewrite the above sentence (from paragraph 2) while keeping its original meaning as used in the story?

- A. I had to open my eyes to the huge pig, skin and head on, splayed open across an oil drum that had been sawed in half lengthwise.”
- B. I had to direct my eyes towards the huge pig, skin and head on, splayed open across an oil drum that had been sawed in half lengthwise.
- C. I had to turn my eyes away from the huge pig, skin and head on, splayed open across an oil drum that had been sawed in half lengthwise.
- D. I had to fix my eyes upon the huge pig, skin and head on, splayed open across an oil drum that had been sawed in half lengthwise.

4) As used in paragraph 5, which is the best definition for materialize?

- A. to be false
- B. to increase in size
- C. to become actual or real
- D. to be concerned with consumer goods.

5) Which literary term best applies to the following quote: “Y’all in thuh country now, gul.”

- A. yarn, meaning an improbable tale
- B. trait, characterized as a habit or tendency in one’s personality
- C. caprice, characterized as expressing fanciful or odd notions
- D. vernacular, meaning the native language of people in a particular geographical area.

6) Which best describes the narrator's attitude in this passage?

- A. disdainful of rural life
- B. unaware of country ways
- C. anxious to get back to Boston
- D. wishful for her children to grow up in the city

7) As used in the middle of the story, which is the best antonym for cursory?

- A. angry and willful
- B. fast and intelligent
- C. slow and deliberate
- D. slow and superficial

8) What does it mean to literally do something?

- A. to think about doing something
- B. to do something exactly as said
- C. to do something and regret it later
- D. to do something with a bad attitude

9) What message does the author convey by having the narrator wait out the storm in a glass room?

- A. It signifies how vulnerable she is.
- B. It signifies the narrator's nontraditional tastes.

C. It lets the reader know that she has not taped up her windows.

D. It lets the reader know she can see everything that's going on.

10) Which lesson does the narrator most likely learn during the hurricane?

A. The early bird catches the worm.

B. Marry in haste and repent at leisure.

C. An ounce of prevention is worth a pound of cure.

D. Actions speak louder than words.



MONDAY

I. Match the words with the definitions.

- | | |
|---------------|--------------------------|
| 0. robber | <input type="checkbox"/> |
| 1. con man | <input type="checkbox"/> |
| 2. mugger | <input type="checkbox"/> |
| 3. pickpocket | <input type="checkbox"/> |
| 4. burglar | <input type="checkbox"/> |
| 5. shoplifter | <input type="checkbox"/> |

- a) A person who steals from another, using violence or the threat of violence.
- b) A person who breaks into houses and steals things.
- c) A person who steals things.
- d) A person who tricks someone into giving them money.
- e) A person who steals from shops.
- f) A person who steals things from people's bags or pockets.

II. Complete the sentences with the words in the list.

committed | arrested | broke | prison | trouble | fine

- 0. The police arrested the burglar as he climbed out of the window.
- 1. I got a _____ of £25 for throwing litter in the park.
- 2. She has never _____ a crime in her life.
- 3. You will be sent to _____ if the police catch you.
- 4. I don't want to get into any _____.
- 5. The police think the burglar _____ in through the back door.

III. Underlined the best verbs to report these statements.

- 0. "OK, I'll meet you at 8 o'clock."

agree / invite

1. "You should go and see that film – it's great."

demand / recommend

2. "Would you like to come to the beach with us this afternoon?"

persuade / invite

3. "No, I won't tell you the answer."

refuse / demand

4. "This new system will reduce crime by 50%."

encourage / claim

5. "I insist that you clean your room right now."

demand / persuade

IV. Complete the sentences.

0. "We want to have CCTV in every street."

They said they **wanted** CCTV cameras in every street.

1. "I think muggers should go to prison."

He said he _____ muggers should go to prison.

2. "They didn't phone me."

She said they _____ her.

3. "I'll call the police."

He said he _____ the police.

4. "We can't arrest him without evidence."

They said they _____ him without evidence.

5. "You're going to get into trouble."

He said I _____ into trouble.

V. Read the text below and think of the word which fits each gap. Use only one word in each gap.

LUXEMBURG

The Grand Duchy of Luxembourg is a constitutional monarchy headed by Grand Duke Henri of the House of Nassau. Economically, the (0) **STRENGHT** of its banking and (1) _____ institutions has attracted more than 200 foreign banks, including the headquarters of the European Investment Bank. The 480,000 (2) _____ have among the highest income levels per capita of any country in the world. Agriculture is still (3) _____. Around half of the total land area is farmed, though less than 5% of Luxembourgers now live and work on farms. Despite problems caused by overproduction of European wines in general, the vineyards are still (4) _____. And the enchanting Luxembourg countryside, (5) _____ its northern reaches in the Ardennes, is a popular holiday destination for Luxembourgers and (6) _____ from neighbouring countries. Having played a key role in establishing the institutions that evolved into the European Union, Luxembourg today hosts the secretariat of the European Parliament. In such a small country, with bigger neighbours on its doorstep, Luxembourgers have a distinctive individuality that even extends to the (7) _____ language, Letzebuergesch, which is vaguely related to both French and German, yet quite different from both.

- STRONG
FINANCE

RESIDE

IMPORT

COMPET
PARTICULAR

VISIT

NATION

TUESDAY

VI. Put the words in the correct order to make sentences.

0. asked / The policeman / where / had / I / me / been

The policeman asked me where I had been.

1. claimed / never / he / had / He / a crime / committed

2. her / to go / Her teacher / to college / encouraged

3. you / I / not to / told / too long / stay out

4. us / They / if / worried / we / about / were / crime / asked

5. agreed / it / We all / a fantastic / had been / holiday

REPORTED SPEECH

DIRECT SPEECH	INDIRECT SPEECH
Simple Present <i>"I never eat meat", he explained.</i>	Simple Past <i>= He explained (that) he never ate meat.</i>
Present Continuous <i>"I'm waiting for Ann", he said.</i>	Past Continuous <i>= He said (that) he was waiting for Ann.</i>
Present Perfect <i>"I have found a flat", he said.</i>	Past Perfect <i>= He said (that) he had found a flat.</i>
Present Perfect Continuous <i>He said, "I've been waiting for ages".</i>	Past Perfect Continuous <i>= He said (that) he had been waiting for ages.</i>
Simple Past <i>"I took it home with me", she said.</i>	Past Perfect <i>= She said (that) he had taken it home with her.</i>
Future <i>He said, "I will/shall be in Paris on Monday".</i>	Conditional <i>= He said (that) he would be in Paris on Monday.</i>
Future Continuous <i>"I will/shall be using the car myself on the 24h", she said.</i>	Conditional Continuous <i>= She said (that) she'd been using the car herself on the 24th.</i>
Conditional <i>I said, "I would like to see it".</i>	Conditional <i>= I said (that) I would like to see it.</i>

VII. Complete the reported questions, requests and commands.

0. "Put your hands up!"
He told him to put his hands up.
1. "When are you going out?"
He asked me _____.
2. "What time did you leave the office?"
The policeman asked her _____.
3. "Have you heard about the burglary?"
She asked him _____.
4. "Don't forget to lock all the doors!"
We told them _____.
5. "What were you doing when you heard the explosion?"
She asked me _____.

VIII. Complete the conversations with the words in the lists.

awful | believe | guess | Really | Tell | What

A: You'll never (0) guess what happened yesterday!

B: (1) _____ ?

A: You won't (2) _____ it.

B: (3) _____ me!

A: I got mugged on my way home from school!

B: (4) _____ ?

A: Yes! It was so scary.

B: That's (5) _____ !

IX. For questions 1-7, read the text below and think of the word which fits each gap. Use only one word in each gap.

HOLIDAYS

Whatever you do in tourism, you are likely to have a (0) **A LOT OF** of contact (1) _____ other people. This can be both enjoyable (2) _____ difficult. You will soon find (3) _____ how often people behave unlike their usual selves while on holiday, or trying to arrange a holiday. (4) _____ they stay in their own country or go abroad, they want to get away from it all, they (5) _____ paying hard-earned money to relax from work, and they want value (6) _____ money.

They will also be in unfamiliar surroundings and unsure of themselves. When things go well their happiness is infectious - it is very rewarding helping (7) _____ and contributing to the enjoyment of their holiday. When things go badly, clients blame the hotel staff or tour operator's representative, even if it isn't their fault. You've just got to keep calm and keep smiling when people are shouting at you.

WEDNESDAY

X. Change the reported speech into mini-dialogues.

0. Steve told Sue he liked her new hairstyle. She told him she'd cut it herself.

I like your new hairstyle.

STEVE

I cut it myself.

SUE

1. Mark asked Tom if he could lend him £5. Tom said he didn't have any money.

_____ ?

MARK

TOM

2. Sonja told Simon not to damage her laptop. Simon said he'd try not to.

_____ ?

SONJA

SIMON

3. James said he'd just seen a fantastic horror film. Jenny said she didn't like horror films.

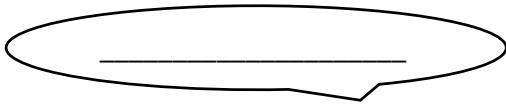

JAMES

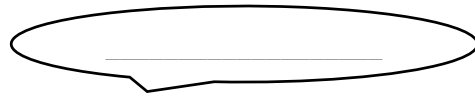

JENNY

4. Sally asked Jim if he had ever committed a crime. Jim said he hadn't.



SALLY



JIM

5. Harry asked Tina if she could play a musical instrument. She told him she couldn't.

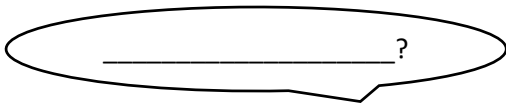

HARRY



TINA

XI. Complete the sentences with the correct forms of the verbs in brackets.

0. Who persuaded you **to have** (have) a barbecue this evening?
1. I hope you apologised for _____ (lose) Sam's pen.
2. My sports teacher encouraged me _____ (take up) climbing.
3. I didn't suggest _____ (leave) your bicycle here.
4. We agreed _____ (not tell) anyone about the crime we had committed.
5. Who recommended that you _____ (join) the police force?

XII. Complete the sentences.

0. "The police are investigating the incident."
He said the police **were** investigating the incident.
1. "Will you open your window, please?"
He asked me if I _____ my window.
2. "Have you found your lost handbag?"
He asked her if she _____ her lost handbag.
3. "Get out of bed!"
She told them _____ of bed.
4. "I can do the shopping for you."
He offered _____ the shopping for me.
5. "I think I'm going to be sick."
She said she _____ to be sick.

XIII. Circle the correct letter.

0. **A:** He said he'd help me find my dog.
B: He said he'll help me find my dog.
1. A: She said she already ate.
B: She said she'd already eaten.
2. A: I asked her if she was feeling ill.
B: I asked her if was she feeling ill.
3. A: Sam encouraged his friend be naughty.
B: Sam encouraged his friend to be naughty.
4. A: I told you to not do that!
B: I told you not to do that!
5. A: He offered to cook dinner that evening.
B: He offered cooking dinner that evening

THURSDAY

XIV. Complete the sentences.

0. "I've decided to become a police officer."
She said **she had decided to become a police officer.**
1. "You really should go training more often."
He encouraged me _____.
2. "No, I won't tell a lie."
She refused _____.
3. "Alright, I'll write Jake's essay."
He agreed _____.
4. "Don't drink the water!"
He told us _____.
5. "I've never met a murderer."
She said _____.

XV. Change the sentences into direct speech.

0. They said they were going to the cinema.
"We're going to the cinema."
1. She asked me if I'd ever been to Paris.
" _____?"

2. He told me not to leave the door open.

“ _____.”

3. She asked him if he'd look after her bags.

“ _____?”

4. They said they couldn't wait any longer.

“ _____.”

5. She said she'd bought a new burglar alarm.

“ _____.”

XVI. Find and correct the mistakes in each sentence.

0. He asked her bring him a sandwich.

He asked her to bring him a sandwich.

1. She told to him she was tired.

_____.

2. I asked him what he is crying about.

_____.

3. She asked me what did I want to watch.

_____.

4. He told that he had been to prison.

_____.

5. I apologised for eat the last sandwich.

_____.

XVII. Complete the second sentence so that it has a similar meaning to the first sentence, using the word given. Do not change the word given. You must use between two and five words, including the word given.

1. Somebody is coming to repair the computer the day after tomorrow.

REPAIRED

I **AM HAVING THE COMPUTER REPAIRED** the day after tomorrow.

2. Mary studied a lot. She wanted to pass the exam.

VIEW

Mary studied a lot with _____ the exam.

3. That's the most stupid excuse I've ever heard.

SUCH

I've never _____ excuse.

4. Please don't go to that conference next week.

RATHER

I'd _____ to that conference next week.

5. Even though he tried hard, he couldn't do anything about it.

MATTER

No _____ tried, he couldn't do anything about it.

6. What's the depth of the lake?' Martha asked her mother.

HOW

Martha asked her mother _____ was.

FRIDAY

XVIII. Read the story. Then answer the questions below.

"Tattoo"

Justin's mom had set down the house rules with aplomb. Only the most **obtuse** person would have failed to understand: no tattoos, no body piercings, and no co-ed sleepovers while living in the house of Elaine Tucker Brown.

Still, the day Justin turned 18, he lied to his mother about where he was going and headed straight to the tattoo parlor, as if **impervious** to his mother's wrath.

He got a light blue heart the size of an orange permanently etched on his arm. Above this work of art was the word "Blessed."

No, Justin was not stupid, but he was obstinate.

Elaine saw this as an act of sheer defiance. She was incensed, her anger **exacerbated** by the fact that Justin had breezed into the house, found her in the kitchen, taken off his shirt with a smile, and said, "Got it!"

"No, Justin. Let me tell you what you've got," Elaine said angrily. "You've got five minutes to go upstairs and pack a bag. I'm taking you to Pop-Pop's."

The ride to Pop-Pop's house was chilly, to say the least. Elaine berated Justin for everything she could think of, which wasn't much because he was a straight-A senior with a full academic scholarship to his top college pick. He had a kind heart and had started a foundation in the ninth grade, which donated used sporting equipment to underprivileged kids in South Africa.

Elaine pulled up to her father's door and ordered Justin out. Not 10 minutes later, her cell phone rang.



“Elaine, have you lost it? You are kicking a boy who is as good as him out of the house for a tattoo – that says ‘Blessed,’ no less?” her father asked, incredulous. “You will miss him so much. Don’t cut off your nose to spite your face, Elaine.

Come pick this young man up.”

Elaine, having grown up obeying most of her parents’ demands, turned her car around and went back to pick up her son. Justin was surprisingly **contrite**. “Sorry for being so disrespectful, Mom,” he said earnestly. “I will try to follow house rules from now on.”

1. What other title would best fit this passage?

- A. “House Rules”
- B. “Visiting Pop-Pop”
- C. "Straight A's"
- D. “Body Piercings”

2. As used in paragraph 1, which is the best antonym for obtuse?

- A. foolhardy
- B. intelligent
- C. passionate
- D. stubborn

3. Which of the following proverbs does Elaine seem to learn by the end of the story?

- A. much ado about nothing
- B. familiarity breeds contempt
- C. no arguments will give courage to the coward
- D. if words suffice not, blows must follow

4. Which of the following proverbs does Justin seem to learn by the end of the story?

- A. look before you leap
- B. pleasure bought with pain hurts
- C. youth’s first duty is reverence to parents
- D. if men had all they wished, they would often be ruined

5. In the final paragraph, the author writes, "Justin was surprisingly contrite." Which of the following is the best way to rewrite the above sentence while keeping its original meaning the same?

- A. Justin was surprisingly relaxed.
- B. Justin was surprisingly remorseful.
- C. Justin had surprisingly lost his bad attitude.
- D. Justin had surprisingly become somber.

6. What was Justin's attitude when he showed his mother the tattoo?
- A. wilfully defiant
 - B. cautiously jubilant
 - C. convincingly contrite
 - D. obviously melodramatic
7. As used in paragraph 2, which is the best antonym for impervious?
- A. elated
 - B. impenetrable
 - C. invigorated
 - D. vulnerable
8. As used in paragraph 4, which is the best antonym for exacerbated?
- A. intensified
 - B. evened
 - C. extinguished
 - D. decreased
9. "You are kicking a boy as good as him out of the house for a tattoo – that says 'Blessed,' no less?"
The above sentence from the story has a grammatical error. Which of the following correctly identifies this error?
- A. good should be well
 - B. him should be he
 - C. 'Blessed,' should be "Blessed,"
 - D. less should be lest
10. Using the passage as a guide, which is the best interpretation of the idiom, "cut off your nose to spite your face," as used in paragraph 8?
- A. calling something bad that is not
 - B. trying to teach something too difficult
 - C. loving a person less for what he has done
 - D. pursuing revenge and hurting yourself in the process



WEEK 4

MONDAY

I. Circle the correct words.

I bought a pair of shoes from the new shop in town six months ago. They were on (0) offer / refund. The original price was £60, but they were selling for £45 – that's 25% (1)

worth / off – and you know I love a (2) **bargain / tip**. But it turned out they weren't good (3) **reward / value** for money. There's already a hole – in them, so I don't think they were (4) **owed / worth** £45. Do you think I should take them back and ask for a (5) **refund / tip**, or am I too late?

II. Complete the conversation with the words in the list.

finance | healthcare | education | employer | salary | qualifications

TOM: Do you know what kind of job you'll want when you finish your (0) education?

JILL: I'm thinking about going into (1) _____. I might become a nurse? What about you?

TOM: Oh, I'm looking for something that pays a bigger (2) _____ than nursing! I want to get into (3) _____ and work for a bank. That's where the money is!

JILL: Do you need to get lots of (4) _____ for that?

TOM: Not really. You just have to impress your (5) _____. If you get results, you'll be rewarded.

III. Circle the correct letter.

0.

a. I'll be ride to school at that time.

b. I'll be riding to school at that time.

1.

a. Our car will have done 50,000 km soon.

b. Our car will be doing 50,000 km soon.

2.

a. How long will you be learning English by the end of this year?

b. How long will you have been learning English by the end of this year?

3.

a. We'll be enjoying the sunshine at this time next week.

b. We'll have enjoyed the sunshine at this time next week.

4.

a. In May, Dad will have been working at this school for 12 years.

b. In May, Dad will have been worked at this school for 12 years.

5.

- a. Will you have had dinner by 8 o'clock?
- b. Will you have to had dinner by 8 o'clock?

IV. Read the text and circle the correct answer for each number.

THE GIANT PANDA

The giant panda is a beloved animal in China. It is regarded (1) ... a national (2) It is found mostly in southwestern China in Sichuan, Shaanxi and Gansu provinces. The giant panda is part of the bear family. It has a white coat with black trimmings around its eyes and on its ears, arms, and legs. Adult pandas can be 5 feet (1.5 meters) long and weigh (3) ... to 330 pounds (150 kilograms). The giant panda leads a (4) ... life, except during the mating season.

It lives in bamboo forests (5) ... the mountains. It can climb trees but lives mainly on the ground. (6) ... most bears, the giant panda does not hibernate. It moves to low-lying areas during the winter in search (7) ... warmer temperatures. The giant panda has a mainly (8) ... diet, eating mostly bamboo shoots and leaves. It also eats insects and small rodents. Giant panda breeding groups are small and isolated from one another.

- | | | | |
|-----------------|-------------|---------------|---------------|
| 0. A) like | B) as | C) to | D) that |
| 1. A) fortune | B) value | C) treasure | D) prize |
| 2. A) down | B) on | C) up | D) off |
| 3. A) solitary | B) alone | C) friendless | D) unsociable |
| 4. A) on | B) at | C) under | D) in |
| 5. A) unlike | B) but | C) owing | D) unlikely |
| 6. A) to | B) of | C) for | D) with |
| 7. A) vegetable | B) vegetate | C) vegetarian | D) vegetation |

TUESDAY

V. Put the words in order to make sentences.

0. finished / by / 9 o'clock / have / I'll / my homework
I'll have finished my homework by 9 o'clock.
1. have / She'll / enough / by / saved / June / money

2. this mess / We'll / sorted / before / have / the end / of the day / out

3. been / for / My parents / have / will / married / in June / 20 years

4. tomorrow / you / Will / decided / by / have ?

5. achieved / you / What / have / you're 30 / by the time / will ?

VI. Complete the sentences with the verbs in the list. Use the future continuous or future perfect simple.

travel | ride | not leave | read | cook | have

0. By tomorrow, I **'ll have been reading** this book for a month!

1. By this time next week, we _____ our bicycles in France.

2. Do you think mum _____ dinner for us by the time we get back?

3. You _____ breakfast between 8 a.m. and 9 a.m. tomorrow.

4. Come and visit me anytime tomorrow – I _____ the house all day.

5. By the end of this trip, we _____ over 5,000km.

VII. Circle the correct form of the verb.

0. You **'ll be spending / 'll have spent** all your money soon if you don't slow down!

1. Come and see me in the library, where I **'ll be studying / 'll have studied**.

2. We **'ll be living / 'll have lived** in this town for two years in January.

3. Will **you be finishing / you have finished** your dinner in 10 minutes time?

4. Don't call James now – he **'ll be working out / 'll have worked out** at the gym.

5. Sam **won't be hearing / won't have heard** the match result yet.

VIII. Read the text below and think of the word which fits each gap. Use only one word in each gap.

THE HISTORY OF PAPER

The history of paper is also the history of human culture and (0)CIVILISATION. The Egyptians, Greeks and Romans wrote on "papyrus", a paper-like material. Today's kind of paper was first developed and used in China. Paper was the most important (1) _____ of information in the past. It was only with increasing paper production that the transfer of (2) _____, education and information to a larger portion of (3) _____ became possible.

With paper emperors were able to administrate large empires more easily. In former times paper was a (4) _____ product, and paper making an art - an art that was often kept secret because of the outstanding (5) _____ of the product. Today paper has changed from a rare artisan material to a commodity product, with a high practical value in communication, in (6) _____, artistic, hygienic, sanitary, and technical applications. Nobody can imagine a word without paper. A large variety of paper grades are produced to suit the special (7) _____ of each application.

CIVILISE

CARRY

KNOW

SOCIAL

VALUE

ADVANCE

EDUCATE

REQUIRE

WEDNESDAY

IX. Write the questions.

0. A: **What will you be doing at 7 a.m. tomorrow?**

B: I'll be taking a shower at 7 a.m. tomorrow.

1. A: _____ ?

B: Maria will be waiting for you when you get there.

2. A: _____ ?

B: They'll be taking a break at 1 o'clock.

3. A: _____ ?

B: No, I won't be working tomorrow.

4. A: _____ ?

B: Matt will be looking after his little sister at 8 o'clock tonight.

5. A: _____ ?

I'll be staying at my aunt's house this weekend.

X. Complete the mini dialogues with the words in the list.

mind | How | awful | What | That's | sorry

0. A: We lost nearly £100!
B: How **awful**.
1. A: Danny didn't get the job he wanted.
B: _____ a real shame.
2. A: My favourite football team lost again.
B: Never _____.
3. A: My mum lost her job at the hospital.
B: I'm really _____ to hear that.
4. A: We've already spent nearly all our holiday money!
B: _____ a pity.
5. A: I don't think I'll ever be able to afford to buy my own flat.
B: _____ sad.

XI. Put the words in order to make sentences.

0. sleeping / by / She'll / be / now
She'll be sleeping by now.
1. be / football / We'll / all / playing / weekend
_____.
2. they / have / by / Will / 6 p.m. / arrived?
_____?
3. in / working / 10 years from now / be / I'll / a bank
_____.
4. wearing / He'll / a red jacket / be / this evening
_____.
5. drunk / coffees / by the end of the day / How many / you / have / will?
_____?

XII. Complete the second sentence so that it has a similar meaning to the first sentence, using the word given. Do not change the word given. You must use between two and five words, including the word given.

- | |
|--|
| <p>1. Tomorrow's conference is postponed and it will be held next month.
PUT</p> <p>Tomorrow's conference has BEEN PUT OFF until next month.</p> |
|--|

<p>2. She prefers watching TV to reading books. RATHER</p> <p>She _____ read books.</p>
<p>3. In his opinion, these two kinds of art are totally different from each other. COMPARISON</p> <p>In his opinion, there is _____ these two kinds of art.</p>
<p>4. 'What do you think of the new health centre?' ASKED</p> <p>She _____ of the new health centre.</p>
<p>5. Fiona doesn't like bananas. She doesn't like grapes either. NOR</p> <p>Fiona likes _____ grapes.</p>
<p>6. It's believed that he was the most handsome boy in our school. TO</p> <p>He is _____ the most handsome boy in our school.</p>

THURSDAY

XIII. Find and correct the mistakes in each sentence.

0. She'll has written three books by the end of 2020.

She'll have written three books by the end of 2020.

1. I'll having another piano lesson at the same time next week.

2. He'll soon have earning enough money to buy a new laptop.

3. How many classes will you be to by the end of today?

4. By that time, I'll be lived in my first apartment.

5. Will you be learned how to drive by the time you're 19?

XIV. Complete the conversation. Use the future continuous form of the verb in brackets.

NICK: Do you want to come out tonight?

JULIE: No, sorry. I (0) 'll be studying (study) until I go to bed.

NICK: What about tomorrow? (1) _____ (you / study) then?

JULIE: No.

NICK: Great. I (2) _____ (wait) for you outside school at 7 p.m. OK?

JULIE: No. I said I (3) _____ (not study), but I (4) _____ (do) something else.

NICK: What (5) _____ (you / do)?

JULIE: I don't know yet.



XV. Answer the questions. Use your own ideas.

0. What will you be doing at this time tomorrow?

I 'll be sitting in this classroom.

1. What will you be doing at 11 a.m. on Saturday?

2. How long will you have been learning English by the end of this year?

3. How many English exercises will you have done by the end of today?

4. Will you be sleeping at 11 p.m. tonight?

5. Will you have left school by the time you are 16?

XVI. For questions 1-7, read the text below and think of the word which fits each gap. Use only one word in each gap.

ALASKA: IT'S A STATE OF MIND

One of the greatest things about Alaska is (0) **THAT** it takes the term casual to new heights. While the state has highly cultivated enclaves, (1) _____ as Anchorage, Alaska's largest city, and Juneau, the state capital (population 31,000), for the most part Alaskans are down-to-earth people. They're friendly bunch, more comfortable in Carhartts and cutoffs (2) _____ cashmere and corduroy. The arts thrive, not only in the larger cities (3) _____ also in the small towns. In their own strong spirited way.

Alaskans embrace their independence and refuse (4) _____ be stereotyped. They'll have a sold-out opera, but only half will dress (5) _____. There (6) _____ ultra-fancy restaurants, but they'll entertain kids with smiles on their faces. For visitors, this translates into a vacation completely devoid (7) _____ stress. Wear your evening gown if you like - it doesn't matter if it's to the local ballgame or burger joint. Anything goes.

XVII. Then answer the questions below**“Dreams”**

The relationship between my mother, sister and me had been cold and inimical for as long as I could remember.

To me, my mother was irrational, hurling hurtful invectives for the slightest infraction. “Don’t matter,” my mother grumbled when I asked her where she moved my watercolour paints. “It ain’t like you got talent.” The time our mailbox got knocked off she somehow got it in her head that I was the culprit. “Never respected nothin’,” I heard her say. And my sister took my mother’s side against me every time. Five years my senior, Tammy seemed not to have a brain in her head. She dithered about everything, incapable of making any firm decision. No matter how often my mother deprecated her— “dumb, ugly, fat”—Tammy made futile attempts to fawn her way back into mother’s good graces.

My father would pontificate, “You three are more alike than you know.”

In April of 2000, my mother kicked us both out of the house. (Dad had been exiled many years before.) After that, my sister and I went our separate ways. It was then that I began having recurring dreams.

In one, I am running to catch up with a woman. Each time I get near, I trip and fall. Another woman, smiling and shouting my name, comes with great alacrity and offers her hand, but when I reach to grab it, she disappears.

In another, a female professor hands me a test. Although I have spent hours studying for it, I know none of the answers. The professor derides me for my poor performance. I watch while she relays my ignorance to the class with comic hilarity.

These dreams were not hard to understand. In fact, it was just the opposite; they were pellucid, and absent any knowledge of dream interpretation, I was still able to devise their significance. I knew that they both reflected the pugnacious relationship I shared with my mother and sister.

However, there was one dream I could never quite construe. I bite into an apple. All my teeth fall out. I had this dream far more than any of the others.

Years later, in an effort to heal our fractious relationship, Mom, Tammy and I elected to go to counselling together. After several sessions, I told my dream about teeth tumbling out of my head.

“My God, Crystal,” said my mother. “I’ve had the exact same dream many times.” “Me, too,” said Tammy solemnly.

Breakthrough? No idea. But I was reminded of the words of my now-dead father. Maybe the three of us are more alike than we know.

1. Which is most likely to make a relationship inimical (paragraph 1)?

- A. great pathos
- B. frequent maledictions
- C. magnanimous gestures
- D. ingenious discussions
- E. heated debates

2. As used in paragraph 2, which is the best synonym for invectives?

- A. insults
- B. names
- C. profanity
- D. words
- E. misfortunes

3. If the story were true, which would best describe its genre?

- A. literary essay, based on a piece of literature
- B. memoir essay, centered on a significant memory from the past
- C. persuasive essay, characterized by choosing a side and refuting other arguments
- D. expository essay, meant to inform the reader of a body of knowledge
- E. satire, in which human folly and vice are held up to scorn, derision, or ridicule

4. How does the relationship between the narrator, her mother, and her sister seem to change from the beginning of passage to end?

- A. from brusque to florid
- B. from egregious to impassive
- C. from enervating to rejuvenating
- D. from destructive to collaborative
- E. from convivial to estranged

5. As used in paragraph 7, which is the best antonym for pellucid?

- A. dirty
- B. frightening
- C. enlightening
- D. strange
- E. unclear

6. "The professor derides me for my poor performance."

Which of the following is the best way to rewrite the above sentence (from paragraph 7) while keeping its original meaning the same?

- A. The professor is in disbelief due to my poor performance.
- B. The professor laughs mockingly at my poor performance.
- C. The professor announces my poor performance.
- D. The professor gives me a failing grade for my poor performance.
- E. The professor gives me a tutorial because of my poor performance.

7. "I bite into an apple. All my teeth fall out."

Which of the following is the best way to rewrite the above sentences (from paragraph 9) while keeping their original meaning the same?

- A. I bite into an apple, so all my teeth fall out.
- B. I bite into an apple, yet all my teeth fall out.
- C. I bite into an apple, and all my teeth fall out.
- D. I bite into an apple, because all my teeth fall out.

E. I bite into an apple, but all my teeth fall out.

8. If the professor in the narrator's dream (paragraph 7) represented someone in her life, who would that person most likely be, and why?

- A. the sister, because she was described in the passage as dithering
- B. the mother, because she was described in the passage as mean-spirited
- C. the narrator, because she seems to be testing everyone in the passage
- D. the father, because he understood that that the three women were alike
- E. herself, **because** she was hyper-aware of her own problems



Inventario de ejercicios, problemas y actividades de Educación Física (primer grado de secundaria) (Apoyo a la recuperación académica 2017)





Estimado estudiante:

Te proponemos el presente inventario de ejercicios y actividades como un recurso de apoyo para el proceso de recuperación académica que debes seguir durante el mes de enero de 2018. Te pedimos tener presente que:

- El inventario ha sido elaborado de acuerdo con la problemática existente en nuestra población estudiantil.
- El inventario ha sido dosificado para ser desarrollado en cuatro semanas, de lunes a viernes, destinando para ello una hora diaria aproximadamente. Es importante que anotes tus resultados en la tabla de control del rendimiento físico. Al final del documento se te presenta una tabla para que obtengas tus puntajes.
- El inventario debe ser desarrollado bajo la supervisión del padre de familia.
- En la tabla de control diario, el padre de familia debe firmar para apoyar y controlar el avance diario del estudiante en el desarrollo del inventario.
- No hemos incluido una calendarización específica para el desarrollo del inventario (fechas de inicio y fin), asumiendo que cada estudiante lo hará en coordinación con sus padres, considerando la realidad particular y los planes de la familia. En todo caso, el trabajo ha sido previsto para cuatro semanas.

Semana 1

Las actividades físicas y deportivas se recomienda que se realicen tres veces por semana, descansando los domingo que son de esparcimiento familiar.

Competencia	Criterios	Tiempo	Ejercicios y actividades	Referencia
Asume una vida saludable.	Alimentación saludable	Antes y después de cualquier actividad física	<ul style="list-style-type: none"> - Consumo de agua - Consumo de fruta - Uso de polo auxiliar - Aseo personal - Uso de bloqueador si está expuesto al Sol 	
		20'	<p>Información ¿Por qué debemos desayunar bien? El desayuno es la primera comida después del ayuno nocturno y afecta de diversas maneras a nuestro organismo:</p> <ul style="list-style-type: none"> - Nos aporta energía para todo el día, en especial para la mañana. - Condiciona nuestro estado de ánimo. - Incide en el rendimiento físico y mental. - Nos permite comer menos cantidad a lo largo del día, ya que nuestro cuerpo no detecta carencias. - Nuestro cuerpo asimila mejor los alimentos que tomamos en ayunas. 	
	Calentamiento	4'	<ul style="list-style-type: none"> - El estudiante realiza movimiento articular 2 s. - Estiramiento en los diferentes segmentos del cuerpo 2 s. 	
		5'	Comienza realizando 12 repeticiones de sentadillas prisionero (con las manos tras la nuca).	

















		5'	Realiza 10 repeticiones de splits con salto (salto con una pierna hacia delante).	
		5'	65 repeticiones de saltos Jack o polichinelas (saltos abriendo y cerrando las piernas mientras abres y cierras los brazos por encima de la cabeza con palmada).	
	Preparación física (resistencia aeróbica)	20'	Sistema de entrenamiento interval training El estudiante tiene que trotar de forma continua por espacio de 2'30" con su propio paso y esfuerzo con un descanso de 1' caminando. Al termino del descanso vuelve a trotar y seguir la secuencia sugerida, se repite la acción por 5 series continuas.	
	Preparación física (fuerza muscular)	10'	El estudiante tiene que realizar fuerza de brazos en la posición de planchas, 3 series de 10 repeticiones. Descanso de 1'30" después de cada serie.	
		10'	El estudiante tiene que realizar fuerza abdominal en la posición clásica con rodillas flexionadas y manos detrás del pabellón de la oreja, su ejecución es de 30" en la cual se debe ejecutar mínimo 20 abdominales cruzados. Descanso después de una serie de 1'30". Este trabajo en su primera semana tiene 3 series bien ejecutadas	
Se desenvuelve de manera autónoma a través de su motricidad.	Preparación técnica y física	60'	Recomendación Los deportes a practicar en verano quedan a libre voluntad del estudiante (fútbol, basquetbol, voleibol, natación, etc.). Si crees conveniente en algún taller o academia deportiva de tu agrado.	
Interactúa a través de sus habilidades sociomotrices.	Preparación de estrategias y tácticas deportivas (trabajo en equipo)	60'	Recomendación El estudiante debe en estas vacaciones ser parte de una agrupación donde se practique algún tipo de deporte de forma competitiva o en la zona donde reside ser parte de un grupo que ejecute acciones de apoyo a la comunidad donde él aplique estrategias y tácticas para el logro de un objetivo común en la práctica de diferentes actividades físicas.	

Tabla de control del rendimiento físico de la semana 1

Control semanal	Fuerza de brazos en 30"	Fuerza abdominal en 30"	Fuerza de piernas (Salto largo sin carrera)	Velocidad (50 m)	Resistencia/Intervalos
Cantidad/distancia tiempo					
Puntaje (Guíate de la tabla anexa)					
Firma					

Las actividades físicas y deportivas se recomienda que se realicen tres veces por semana, descansando los domingo que son de esparcimiento familiar.

Competencia	Capacidades	Tiempo	Ejercicios y actividades	
Asume una vida saludable.	Alimentación saludable	20'	<p>Información</p> <p>El almuerzo</p> <p>El almuerzo es una comida diaria muy importante y además de gran relevancia cultural, gracias a ese pequeño descanso podemos comer algo para reponer energías, porque desde el desayuno no se han ingerido más alimentos y con el paso de las horas el cuerpo necesita más energía para afrontar de forma satisfactoria las actividades que se vayan a realizar, en el caso de los niños, les ayudará tanto físicamente como mentalmente durante el horario escolar.</p>	
	Calentamiento	4'	<ul style="list-style-type: none"> - El estudiante realiza movimiento articular 2'. - Estiramiento en los diferentes segmentos del cuerpo 2' 	
		5'	8 repeticiones de burpee (De pie, nos aguachamos a tocar el suelo con las manos, echamos las piernas atrás, realizamos un fondo y nos levantamos para dar un salto).	
		5'	30 segundos de abdominales oblicuos plank para cada lado.	
		5'	65 repeticiones de saltos Jack o polichinelas (saltos abriendo y cerrando las piernas mientras abres y cierras los brazos por encima de la cabeza con palmada).	
	Preparación física (velocidad)	10'	El estudiante inicia en cualquiera de los conos realizando diagonales, laterales y carreras de espalda a velocidad y con cambios de ritmo.	
	Preparación física (resistencia aeróbica)	20'	<p>Sistema de entrenamiento interval training</p> <p>El estudiante tiene que trotar de forma continua por espacio de 2'30" con su propio paso y esfuerzo con un descanso de 1' caminando. Al termino del descanso vuelve a trotar y seguir la secuencia sugerida, se repite la acción por 5 series continuas.</p>	
	Preparación física (fuerza muscular)	10'	<ul style="list-style-type: none"> - 8 repeticiones de dominadas con agarre hacia adentro - 3 series 	
10'		<ul style="list-style-type: none"> - 10 repeticiones de abdominal puente - 3 series 		
Se desenvuelve de manera autónoma a través de su motricidad.	Preparación técnica y física	60'	<p>Recomendación</p> <p>Los deportes a practicar en verano quedan a libre voluntad del estudiante (fútbol, basquetbol, voleibol, natación, etc.). Si crees conveniente en algún taller o academia deportiva de tu agrado.</p>	





Interactúa a través de sus habilidades sociomotrices.	Preparación de estrategias y tácticas deportivas (trabajo en equipo)	60'	Recomendación El estudiante debe en estas vacaciones ser parte de una agrupación donde se practique algún tipo de deporte de forma competitiva o en la zona donde reside ser parte de un grupo que ejecute acciones de apoyo a la comunidad donde él aplique estrategias y tácticas para el logro de un objetivo común en la práctica de diferentes actividades físicas.	
---	--	-----	--	--

Tabla de control del rendimiento físico de la semana 2

Control semanal	Fuerza de brazos en 30"	Fuerza abdominal en 30"	Fuerza de piernas (Salto largo sin carrera)	Velocidad (50 m)	Resistencia/Intervalos
Cantidad/distancia tiempo					
Puntaje (Guíate de la tabla anexa)					
Firma					

Semana 3

Las actividades físicas y deportivas se recomienda que se realicen tres veces por semana, descansando los domingos que son de esparcimiento familiar.

Competencia	Capacidades	Tiempo	Ejercicios y actividades	
Asume una vida saludable.	Alimentación saludable	20'	Información Beneficios y perjuicios de la cena La cena es la última comida del día, y su función es la de acostarnos con el estómago vacío y contribuir a un buen descanso, pero sin embargo no debe ser una cena tan nutritiva como el desayuno o el almuerzo, ya que apenas vamos a gastar energía durante la noche. Por eso es importante que hagamos la cena temprana o bien ligera. Cuando cenamos de manera copiosa, demasiado tarde, o incluyendo alimentos poco saludables, podemos notar algunos de los siguientes efectos en nuestra salud: <ul style="list-style-type: none"> - Insomnio, falta de descanso y cansancio por la mañana - Aspecto ojeroso y apagado en el rostro - Retención de líquidos - Estreñimiento - Mucosidades al despertar - Problemas hepáticos y malas digestiones, con acidez, flatulencias, etc. - A la larga, sobrepeso o falta de peso 	
	Calentamiento	4'	Ejercicios de movilidad para el cuello <ul style="list-style-type: none"> - Inclina la cabeza hacia la izquierda y sujétala con una mano, baja el hombro derecho. Cuenta hasta diez. Realiza el mismo ejercicio hacia el otro lado, repitiendo 3 veces cada lado. - Gira la cabeza hacia ambos lados procurando que la barbilla se toque con el hombro correspondiente. - Gira la cabeza en el sentido de las agujas del reloj, despacio y con movimiento suave, para impedir posibles mareos y contracturas. 	
		5'	8 repeticiones de burpee. (De pie, nos agachamos a tocar el suelo con las manos, echamos las piernas atrás, realizamos un fondo y nos levantamos para dar un salto).	















		5'	30 segundos de abdominales oblicuos plank para cada lado.	
		5'	65 repeticiones de saltos Jack o polichinelas (saltos abriendo y cerrando las piernas mientras abres y cierras los brazos por encima de la cabeza con palmada).	
	Preparación física (velocidad)	10'	El estudiante inicia en cualquiera de los conos realizando diagonales, laterales y carreras de espalda a velocidad y con cambios de ritmo.	
	Preparación física (resistencia aeróbica)	20'	Sistema de entrenamiento interval training El estudiante tiene que trotar de forma continua por espacio de 2'30" con su propio paso y esfuerzo con un descanso de 1' caminando. Al termino del descanso vuelve a trotar y seguir la secuencia sugerida, se repite la acción por 5 series continuas.	
	Preparación física (fuerza muscular)	10'	8 repeticiones de dominadas con agarre hacia adentro (3 series)	
		10'	10 repeticiones de abdominal puente (3 series)	
Se desenvuelve de manera autónoma a través de su motricidad.	Preparación técnica y física	60'	Recomendación Los deportes a practicar en verano quedan a libre voluntad del estudiante (fútbol, basquetbol, voleibol, natación, etc.). Si crees conveniente en algún taller o academia deportiva de tu agrado.	
Interactúa a través de sus habilidades sociomotrices.	Preparación de estrategias y tácticas deportivas (trabajo en equipo)	60'	Recomendación El estudiante debe en estas vacaciones ser parte de una agrupación donde se practique algún tipo de deporte de forma competitiva o en la zona donde reside ser parte de un grupo que ejecute acciones de apoyo a la comunidad donde él aplique estrategias y tácticas para el logro de un objetivo común en la práctica de diferentes actividades físicas.	

Tabla de control del rendimiento físico de la semana 3

Control semanal	Fuerza de brazos en 30"	Fuerza abdominal en 30"	Fuerza de piernas (Salto largo sin carrera)	Velocidad (50 m)	Resistencia/Intervalos
Cantidad/distancia tiempo					
Puntaje (Guíate de la tabla anexa)					
Firma					

Las actividades físicas y deportivas se recomienda que se realicen tres veces por semana, descansando los domingo que son de esparcimiento familiar

Competencia	Capacidades	Tiempo	Ejercicios y actividades	
Asume una vida saludable.	Alimentación saludable	Durante el día	<p>Información</p> <p>5 comidas al día</p> <p>Cinco comidas al día nos ayudarán a mantener mejor nuestro régimen, básicamente por una serie de factores:</p> <ul style="list-style-type: none"> - Logran que nuestro metabolismo no retenga tan fácilmente las grasas. Cuando pasamos muchas horas sin comer, el sistema digestivo activa un mecanismo de autoprotección consistente en retener grasas para intentar, de ese modo, asegurarse el alimento ante una previsible, fase de carestía. Comiendo a menudo desactivamos esa "fase de emergencia", por lo tanto, retenemos menos grasas. - La sensación de hambre disminuye porque, lógicamente, hemos ingerido más alimentos. Eso nos hará comer con menos ansiedad y en menor cantidad cada vez que consumamos algún alimento - El hecho de que comamos cinco veces al día elimina la posibilidad del famoso "picoteo" entre horas, lo cual nos evitará, con casi toda seguridad, el que ingiramos los alimentos "chatarra" tan desaconsejables. 	
	Calentamiento	4'	<p>Ejercicios de movilidad para el tobillo</p> <p>Coloca el pie en una posición que pueda marcar un ángulo de 90 grados con la pierna. El dorso de tu pie debe de quedar frente a ti. Mantén la rodilla recta por lo menos 10 segundos y regresa a la posición neutral. Repite los pasos anteriores 10 veces.</p> <p>Como regla general, ten en cuenta que el ejercicio se prolonga hasta que sientas un calor localizado muy intenso en la zona que trabajas, y hasta cierta fatiga de los músculos implicados en el movimiento. Como regla general trabaja de arriba hacia abajo, es decir del cuello a los tobillos, y siempre antes de esfuerzos que impliquen movimientos explosivos o a gran velocidad.</p>	
		5'	8 repeticiones de burpee. (De pie, nos aguachamos a tocar el suelo con las manos, echamos las piernas atrás, realizamos un fondo y nos levantamos para dar un salto).	
		5'	30 segundos de abdominales oblicuos plank para cada lado.	
	5'	65 repeticiones de saltos Jack o polichinelas (saltos abriendo y cerrando las piernas mientras abres y cierras los brazos por encima de la cabeza con palmada).		
Preparación física (velocidad)		10'	<p>El entrenamiento de la velocidad</p> <p>Es imprescindible hacerlo al 100 % de tu capacidad. Es decir, debes ejercitarte a la mayor velocidad posible, de lo contrario no podrías estimular esta capacidad condicionante.</p> <p>Por la gran intensidad de trabajo que despliegas, los ejercicios para ganar velocidad se limitan a unos pocos segundos (hasta 8-10 segundos como límite) y los tiempos de recuperación son completos (3 minutos como mínimo).</p>	







	Preparación física (resistencia aeróbica)	20'	Sistema de entrenamiento interval training El estudiante tiene que trotar de forma continua por espacio de 2'30" con su propio paso y esfuerzo con un descanso de 1' caminando. Al termino del descanso vuelve a trotar y seguir la secuencia sugerida, se repite la acción por 5 series continuas.	
	Preparación física (fuerza muscular)	10'	Fuerza para brazos para potenciar los tríceps Necesitarás la ayuda de un banco fijo que esté a la altura de tus rodillas, aproximadamente. Colócate de la forma que ves en la imagen. El ejercicio consiste en estirar y flexionar los brazos, de modo que tengan que soportar todo el peso de tu cuerpo durante la ejecución. Haz 3 series con 10 repeticiones.	
		10'	Abdominales marcados Tenemos que remarcar que para poder tener unos resultados visibles es imprescindible que seas constante y que cuides tu alimentación pues, una de las claves que existen para poder tener las abdominales marcadas, es eliminar la grasa de tu cuerpo y esto tan solo se consigue con una alimentación saludable y la práctica de ejercicio físico. En esta posición deberás elevar ligeramente las piernas procurando mantener el cuerpo completamente recto y tendrás que ir moviendo las piernas, una por debajo de la otra y viceversa, para hacer este ejercicio. Aguanta 30 segundos haciendo este ejercicio y, después, descansa otros 20.	<ol style="list-style-type: none">  
Se desenvuelve de manera autónoma a través de su motricidad.	Preparación técnica y física	60'	Recomendación Los deportes a practicar en verano quedan a libre voluntad del estudiante (fútbol, basquetbol, voleibol, natación, etc.). Si crees conveniente en algún taller o academia deportiva de tu agrado.	
Interactúa a través de sus habilidades sociomotrices.	Preparación de estrategias y tácticas deportivas (trabajo en equipo)	60'	Recomendación El estudiante debe en estas vacaciones ser parte de una agrupación donde se practique algún tipo de deporte de forma competitiva o en la zona donde reside ser parte de un grupo que ejecute acciones de apoyo a la comunidad donde él aplique estrategias y tácticas para el logro de un objetivo común en la práctica de diferentes actividades físicas.	

Tabla de control del rendimiento físico de la semana 4					
Control semanal	Fuerza de brazos en 30"	Fuerza abdominal en 30"	Fuerza de piernas (Salto largo sin carrera)	Velocidad (50 m)	Resistencia/Intervalos
Cantidad/distancia tiempo					
Puntaje (Guíate de la tabla anexa)					
Firma					

Juan Carlos Pérez Sánchez
Prof. Educación Física

Alejandro Enrique Cipriano Navarrete
Prof. Educación Física

Tabla anexa

EVALUACIÓN DE RENDIMIENTO FÍSICO
12 A 13 AÑOS

NIVEL DE LOGRO	PUNTOS	FUERZA MUSCULAR						VELOCIDAD (SEG)		RESISTENCIA (MIN)	
		BRAZOS (30 SEG) 10 PTOS		ABDOMINALES (30 SEG) 10 PTOS		PIERNAS SALTO LARGO SIN IMPULSO 10 PTOS		50 METROS PLANOS PARTIDA ALTA 10 PTOS		1000 m VARONES 10 PUNTOS	800 m DAMAS 10 PUNTOS
E	10	20 o más	20 o más	29 o más	24 o más	1,70 m	1,50 m	7,5	8,0	4,15	4,00
B	9	18	18	26	21	1,60	1,40	7,9	8,5	4,30	4,15
	8	16	16	22	18	1,50	1,30	8,3	9,0	4,40	4,30
R	7	14	14	19	15	1,40	1,20	8,5	9,3	4,50	4,50
	6	12	12	17	13	1,35	1,15	9,0	9,8	5,00	5,10
	5	10	10	15	11	1,30	1,10	9,2	10,2	5,10	5,20
D	4	8	8	13	9	1,25	1,05	9,5	10,5	5,20	5,30
	3	6	6	11	7	1,20	1,00	9,8	10,8	5,30	5,40
	2	4	4	9	5	1,15	0,95	10,0	11,0	5,40	5,50
	1	2	2	7	3	1,10	0,90	10,5	11,5	6,00	6,00
	0	N/P	N/P	N/P	N/P	N/P	N/P	N/P	N/P	N/P	N/P
		M	F	M	F	M	F	M	F	M	F



Inventario de ejercicios, problemas y actividades de Arte (primer grado de secundaria) (Apoyo a la recuperación académica 2017)

Estimado estudiante:

Te proponemos el presente inventario de ejercicios prácticos, como un recurso de apoyo para el proceso de recuperación académica que debes seguir durante el mes de enero de 2018. Te pedimos tener presente, respecto al inventario, lo siguiente:

- Ha sido elaborado de acuerdo con los temarios de las evaluaciones de salida.
- Los ejercicios prácticos que se presentan en él han sido tomados de los documentos de trabajo del año escolar 2017 y de otras fuentes, pero que se ajustan a los contenidos del temario.
- Ha sido dosificado para ser desarrollado en cuatro semanas, de lunes a viernes, destinando para ello una hora diaria aproximadamente.
- Deben ser desarrollados en papel bond A4 blanco. Su presentación será en un fólter manila tamaño A4 (incluir carátula), el mismo que será revisado y evaluado por el docente responsables de la evaluación de recuperación, asignándole un peso de 25 % en el resultado final de la recuperación como "evaluación de portafolio". De hecho, si no lo presentas desarrollado, se te asignará la nota mínima en evaluación de portafolio.
- Si los estudiantes requiriesen presentarse a la segunda oportunidad, podrán mejorar y volver a presentarlo desarrollado, prevaleciendo, en este caso, la segunda calificación. Si no lo hiciesen, mantendrán la calificación obtenida en la primera ocasión.
- En la tabla de control diario, el padre de familia debe firmar para apoyar y controlar el avance diario del estudiante en su desarrollo.
- No hemos incluido una calendarización específica para su desarrollo (fechas de inicio y fin), asumiendo que cada estudiante lo hará en coordinación con sus padres, considerando la realidad particular y los planes de la familia. En todo caso, el trabajo ha sido previsto para cuatro semanas.
- La primera oportunidad de evaluación será a fines de enero. La presentación del portafolio (inventario desarrollado) es obligatoria desde la primera oportunidad de evaluación.

Semana 1

Tema 1: Dibujo técnico: Diseños lineales con escuadras

- Imprime las láminas de los **anexos 1 y 2**. A continuación, dibuja los diseños propuestos. No olvides de leer las recomendaciones.

Tabla de firmas del padre de familia de control diario de la semana 1				
	Martes 2 de enero	Miércoles 3 de enero	Jueves 4 de enero	Viernes 5 de enero

Semana 2

Tema 2: Dibujo técnico: Diseños lineales con escuadras y compás

- Imprime las láminas de los **anexos 3 y 4**. A continuación, dibuja los diseños propuestos. No olvides de leer las recomendaciones.

Tabla de firmas del padre de familia de control diario de la semana 1				
	Martes 2 de enero	Miércoles 3 de enero	Jueves 4 de enero	Viernes 5 de enero

Semana 3

Tema 3: Dibujo artístico: (técnica del lápiz carboncillo).

- Imprime la lámina del **anexo 5**. A continuación, dibuja el diseño propuesto. No olvides de leer las recomendaciones.

Tabla de firmas del padre de familia de control diario de la semana 1				
	Martes 2 de enero	Miércoles 3 de enero	Jueves 4 de enero	Viernes 5 de enero

Semana 4

Tema 4: Dibujo artístico: (técnica de los lápices de color).

- Imprime la lámina del **anexo 6**. A continuación, dibuja el diseño propuesto. No olvides de leer las recomendaciones.

Tabla de firmas del padre de familia de control diario de la semana 1				
	Martes 2 de enero	Miércoles 3 de enero	Jueves 4 de enero	Viernes 5 de enero

Tabla de puntajes						
Semana 1		Semana 2		Semana 3	Semana 4	Puntaje
Lámina 1	Lámina 2	Lámina 3	Lámina 4	Lámina 5	Lámina 6	
3 puntos	3 puntos	3 puntos	3 puntos	4 puntos	4 puntos	

Detalles

Dibujo técnico	
Puntaje	Detalle
3 puntos	Lámina totalmente concluida de acuerdo al requerimiento propuesto.
2 puntos	Lámina con más del 50 % concluida de acuerdo al requerimiento propuesto.
1 punto	Lámina con menos del 50 % concluida de acuerdo al requerimiento propuesto.
0 punto	No presentó su lámina.

Dibujo artístico	
Puntaje	Detalle
4 puntos	Lámina totalmente concluida de acuerdo al requerimiento propuesto.
3 puntos	Lámina con más del 75 % concluida de acuerdo al requerimiento propuesto.
2 puntos	Lámina con más del 50 % concluida de acuerdo al requerimiento propuesto.
1 punto	Lámina con menos del 50 % concluida de acuerdo al requerimiento propuesto.
0 punto	No presentó su lámina.

Con las medidas dadas, dibuja con escuadras y lápiz 2H el diseño de la derecha. Delinéalo con fine pen negro. A continuación, usa tus lápices de colores para pintar el diseño.

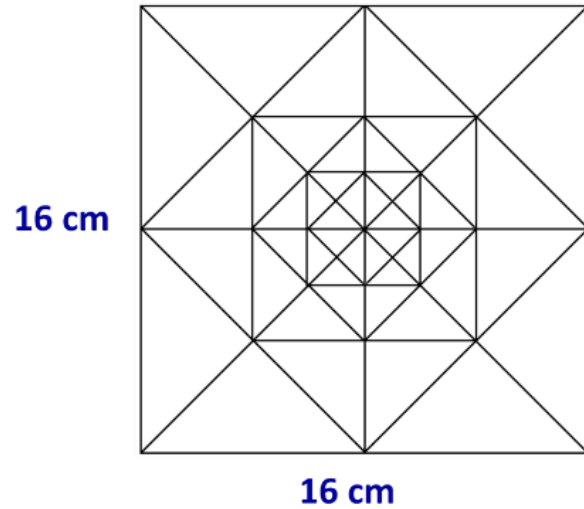

CEP Nuestra Señora del Perpetuo Socorro
El estudio, tan natural como el juego y el descanso

Con las medidas dadas, dibuja con escuadras y lápiz 2H el siguiente diseño lineal, lo delinea con fine pen negro y lo coloreas con los colores de tu preferencia.

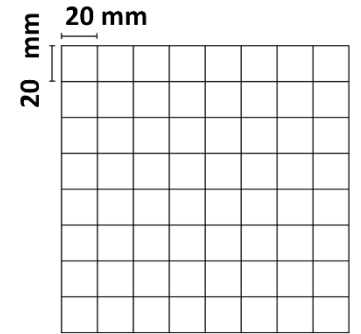
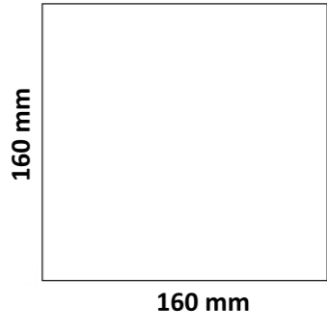

Anexo 2

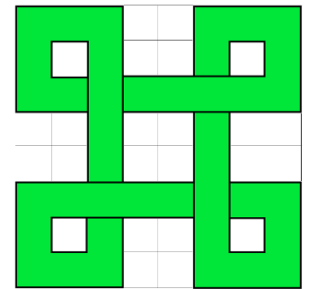
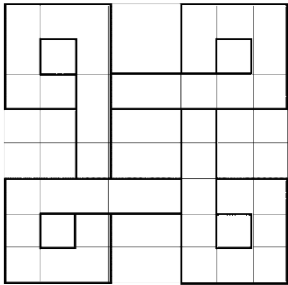

CEP Nuestra Señora del Perpetuo Socorro
El estudio, tan natural como el juego y el descanso

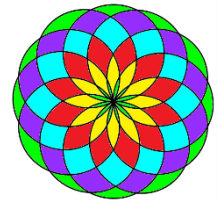
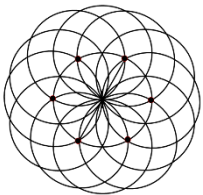
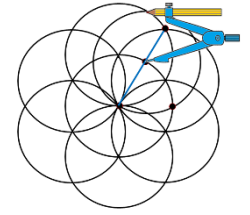
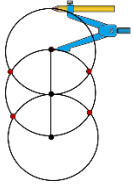

Anexo3

Como en el ejemplo mostrado, dibuja 2 diseños gráficos con compás, fine pen negro y lápices de colores, utilizando como punto de partida las líneas verticales.

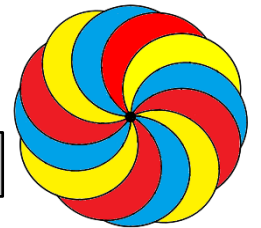
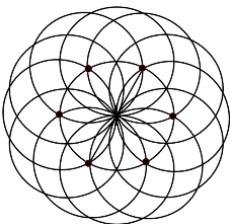
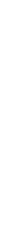
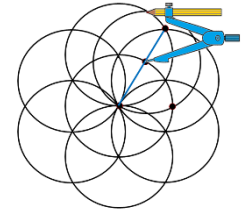
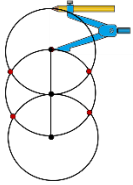

Anexo 4

Como en el ejemplo mostrado, dibuja 2 diseños gráficos con compás, fine pen negro y lápices de colores, utilizando como punto de partida las líneas verticales.

 <p>CEP Nuestra Señora del Perpetuo Socorro <small>El estudio, tan natural como el juego y el descanso</small></p>	<p>Arte</p>	<p>Lámina n.º 4</p>	<p>Dibujado por:</p>	<p>Cambridge English School <small>using Cambridge English exams & materials</small></p>	<p>Código: S1-__-__</p>	<p>Revisado por: Enrique Parks Arellano</p>	<p> Pequeños detalles que nos hacen mejores personas <small>ACREDITACIÓN INTERNACIONAL CNEP - CCEC (2014 - 2019)</small></p>
---	-------------	--------------------------------	----------------------	--	-----------------------------	---	--

Anexo 5

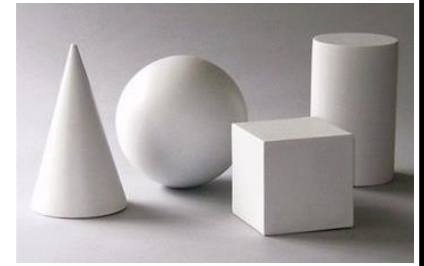

Dibuja el bodegón con lápiz carboncillo, tomando en cuenta encuadre, proporción y degradación.

 <p>CEP Nuestra Señora del Perpetuo Socorro <small>El estudio, tan natural como el juego y el descanso</small></p>	<p>Arte</p>	<p>Lámina n.º 5</p>	<p>Dibujado por:</p>	<p>Cambridge English School <i>using Cambridge English exams & materials</i></p>	<p>Código: S1-__-__</p>	<p>Revisado por: Enrique Parks Arellano</p>	<p> Pequeños detalles que nos hacen mejores personas <small>ACREDITACIÓN INTERNACIONAL CNEP - CCEC (2014 - 2019)</small></p>
---	-------------	--------------------------------	----------------------	---	------------------------------------	--	--

Anexo 6



Dibuja el diseño propuesto con lápices de color, tomando en cuenta encuadre, proporción, degradación y armonía de color.

 <p>CEP Nuestra Señora del Perpetuo Socorro <small>El estudio, tan natural como el juego y el descanso</small></p>	<p>Arte</p>	<p>Lámina n.º 6</p>	<p>Dibujado por:</p>	<p>Cambridge English School <i>using Cambridge English exams & materials</i></p>	<p>Código: S1-__-__</p>	<p>Revisado por: Enrique Parks Arellano</p>	<p> mejores personas <small>Pequeños detalles que nos hacen ACREDITACIÓN INTERNACIONAL CNEP - CCEC (2014 - 2019)</small></p>
---	-------------	--------------------------------	----------------------	---	------------------------------------	--	--



Inventario de ejercicios, problemas y actividades de CIETEC (primer grado de secundaria) (Apoyo a la recuperación académica 2017)

Estimado estudiante:

Te proponemos el presente inventario de ejercicios y problemas (actividades para otras áreas) como un recurso de apoyo para el proceso de recuperación académica que debes seguir durante el mes de enero de 2018. Te pedimos tener presente, respecto al inventario, lo siguiente:

- Ha sido elaborado de acuerdo con el temario de la evaluación de salida del cuarto bimestre.
- Los ejercicios y problemas que se presenta en él han sido tomados de los documentos de trabajo del año escolar 2017 y de otras fuentes, pero que se ajustan a los contenidos del temario.
- Ha sido dosificado para ser desarrollado en cuatro semanas, de lunes a viernes, destinando para ello una hora diaria aproximadamente.
- Debe ser desarrollado en pliegos de papel oficio cuadriculado. Su presentación será en un fólder manila tamaño oficio (incluir carátula), el mismo que será revisado y evaluado por los docentes responsables de la evaluación de recuperación, asignándole un peso de 25 % en el resultado final de la recuperación como "evaluación de portafolio". De hecho, si no lo presentares desarrollado, se te asignará la nota mínima en evaluación de portafolio.
- Si los estudiantes requiriesen presentarse a la segunda oportunidad, podrán mejorar y volver a presentarlo desarrollado, prevaleciendo, en este caso, la segunda calificación. Si no lo hiciesen, mantendrán la calificación obtenida en la primera ocasión.
- En la tabla de control diario, el padre de familia debe firmar para apoyar y controlar el avance diario del estudiante en su desarrollo.
- No hemos incluido una calendarización específica para su desarrollo (fechas de inicio y fin), asumiendo que cada estudiante lo hará en coordinación con sus padres, considerando la realidad particular y los planes de la familia. En todo caso, el trabajo ha sido previsto para cuatro semanas.
- La primera oportunidad de evaluación será a fines de enero. La presentación del portafolio (inventario desarrollado) es obligatoria desde la primera oportunidad de evaluación.

Semana 1

Tema 1: Magnitudes físicas

1. Completar : medir es.....una magnitud con otra.
A. Colocar B. tomar C. llevar D. comparar E. sortear
2. No es una magnitud fundamental :
A. Longitud B. masa C. intensidad de Corriente D. temperatura E. aceleración
3. Es una magnitud fundamental :
A. Densidad B. presión C. fuerza D. temperatura E. aceleración
4. De las siguientes magnitudes, ¿cuántas son fundamentales?
Masa, velocidad, presión, tiempo, intensidad luminosa y temperatura.
A. 1 B. 2 C. 3 D. 4 E. 5
5. En el sistema internacional (SI), la fuerza se mide en:
A. Newton B. Joule C. segundos D. Fahrenheit E. moles
6. En el sistema internacional (SI) el tiempo se mide en:
A. horas B. minutos C. segundos D. gramos E. días
7. En el sistema internacional (SI) , la longitud se mide en:
A. kilómetros B. toneladas C. metros D. milímetros E. hectárea
8. En el sistema internacional SI , la temperatura se mide en:
A. Celsius B. Fahrenheit C. Centígrados D. Kelvin E. Rankine

9. En el sistema internacional (SI) , la masa se mide en:
 A. gramos B. toneladas C. miligramos D. kilogramos E. metros
10. En el sistema internacional SI , la intensidad luminosa se mide en:
 A. amperios B. voltios C. segundos D. moles E. candelas
11. Las magnitudes fundamentales son :
 A. 2 B. 7 C. 8 D. 9 E. 11
12. No es una magnitud fundamental:
 A. longitud B. tiempo C. velocidad D. temperatura E. masa
13. Escribe al lado de cada magnitud si es fundamental o derivada, y además si es escalar o vectorial.
 A. Masa: _____
 B. Tiempo: _____
 C. Energía: _____
 D. Aceleración: _____
14. Es una magnitud fundamental:
 A. densidad B. presión C. fuerza D. aceleración E. temperatura
15. El símbolo correcto del metro es:
 A. mt B. m C. m. D. mts E. m/s
16. El símbolo correcto del kilogramo es:
 A. K B. KG C. Kg D. g E. km
17. El símbolo correcto del segundo es:
 A. S B. seg C. Seg D. s E. h
18. No es magnitud derivada:
 A. fuerza B. trabajo C. energía D. temperatura E. aceleración
19. Es una magnitud derivada:
 A. temperatura B. tiempo C. longitud D. masa E. aceleración

Tema 2: Calor y escalas de temperatura

20. Teóricamente las moléculas de un cuerpo deben cesar su movimiento a una temperatura de:
 A. $-273\text{ }^{\circ}\text{C}$ B. $0\text{ }^{\circ}\text{C}$ C. $32\text{ }^{\circ}\text{C}$ D. $100\text{ }^{\circ}\text{C}$ E. $273\text{ }^{\circ}\text{C}$
21. Según la teoría del calor afirmamos que “El calor es una forma especial de y la temperatura mide el grado de..... molecular”
 A. Fuerza – perturbación
 B. Energía – agitación
 C. Energía – calor
 D. Trabajo – movimiento
22. En un día de verano el termómetro marca $30\text{ }^{\circ}\text{C}$, ¿cuánto marcará en Fahrenheit?
 A. $22\text{ }^{\circ}\text{F}$ B. $30\text{ }^{\circ}\text{F}$ C. $54\text{ }^{\circ}\text{F}$ D. $86\text{ }^{\circ}\text{F}$ E. $92\text{ }^{\circ}\text{F}$
23. Un niño del CEP Nuestra Señora del Perpetuo Socorro, se siente enfermo y está con fiebre. Si en un termómetro, con la escala Fahrenheit su temperatura es $101,3\text{ }^{\circ}\text{F}$. ¿Qué temperatura tiene en la escala centígrada?
 A. $38\text{ }^{\circ}\text{C}$ B. $38,5\text{ }^{\circ}\text{C}$ C. $39\text{ }^{\circ}\text{C}$ D. $40\text{ }^{\circ}\text{C}$ E. $41\text{ }^{\circ}\text{C}$
24. Un termómetro en la escala Celsius marca $28\text{ }^{\circ}\text{C}$. En un termómetro graduado en la escala Fahrenheit es:
 A. $17,4\text{ }^{\circ}\text{F}$ B. $26,4\text{ }^{\circ}\text{F}$ C. $82,4\text{ }^{\circ}\text{F}$ D. $86,6\text{ }^{\circ}\text{F}$ E. $100,8\text{ }^{\circ}\text{F}$
25. Para asar un pollo a la brasa se necesita que el horno alcance una temperatura de $372,2\text{ }^{\circ}\text{F}$, ¿a qué temperatura debe fijarse el graduador para asar el pollo si la graduación está en $^{\circ}\text{C}$?
 A. $128,5\text{ }^{\circ}\text{C}$ B. $159,4\text{ }^{\circ}\text{C}$ C. $189\text{ }^{\circ}\text{C}$ D. $192\text{ }^{\circ}\text{C}$ E. $325,2\text{ }^{\circ}\text{C}$

26. ¿Cuál es la unidad de temperatura en el Sistema Internacional?

- A. K B. °C C. °F D. R E. S

27. El estaño se funde a 503 K. En un termómetro Fahrenheit, esta temperatura se leerá como:

- A. 273 °C B. 340 °C C. 430 °C D. 446 °C E. 500 °C

28. Se tiene dos trozos de hierro de igual masa y forma, siendo la temperatura de uno de ellos -13 °F y el otro 253 K. La temperatura en °C del trozo más caliente es:

- A. -25 °C B. -20 °C C. -10 °C D. 10 °C E. 20 °C

Tema 3: Atmósfera. Capas y características. Hacer un esquema no estructurado sobre las características de las capas de la atmósfera, **guíate de tu separata.**

Tema 4: Reino fungi o hongo. Elaborar un mapa conceptual, **guíate de tu separata.**

Tema 5: Reproducción de las plantas. Explica el proceso de reproducción de una planta. **Guíate de tu separata y practica de laboratorio.**

Tema 6: El fruto. Escoge seis frutas diferentes y ábreelas. Identifica sus partes básicas de cada fruto, clasifícalas y dibújalas. **Guíate de tu separata.**

Tabla de respuestas de la semana 1							
1.		8.		15.		22.	D
2.		9.		16.		23.	B
3.		10.		17.		24.	C
4.		11.		18.		25.	C
5.		12.		19.		26.	
6.		13.		20.		27.	D
7.		14.		21.		28.	B

Tabla de firmas del padre de familia de control diario de la semana 1				
	Martes 2 de enero	Miércoles 3 de enero	Jueves 4 de enero	Viernes 5 de enero